

# OWNER'S MANUAL



**WESTERLY**  
**Westerly Yachts Limited**

Designers and builders of fine craft

Aston Road

Waterlooville

Hampshire

PO7 7XJ

Tel: (STD0705) 254511

## INTRODUCTION

This manual is provided to give Westerly yacht owner's an insight to the construction, operation and maintenance of a new Westerly yacht.

Westerly Yachts warrants the performance of its vessels to current specifications in accordance with Westerly Yachts standard warranty.

Westerly Yachts reserves the right to improve its vessels or specifications identified in this publication without notice.

Specifications contained in this Publication (Westerly Yachts Owner's Manual - Issue 1) supersede all data published by Westerly Yachts before March 1988.

Westerly Yachts will not be held liable for any personal injuries or damage occurring as a result of misuse or badly maintained equipment.

Westerly Yachts advanced design and construction requires the strictest of quality control, using high quality BS approved raw materials and ancillary component manufacturers.

Adherence to this Owner's Manual will ensure many years of trouble free sailing. Remember a well maintained yacht is ultimately more reliable and retains a higher resale value. For further information relating to After Sales Service contact After Sales Manager on (STD 0705) 256406.

# CONTENTS

Title	Page
INTRODUCTION	(ii)
CONTENTS	(iii)
EQUIPMENT CHART - CURRENT YACHTS	(vi)
SECTION 1 - HULL	
Construction	1.1
Skin Fittings and Seacocks	1.2
Cathodic Protection	1.4
Antifouling	1.5
SECTION 2 - SAILS AND RIGGING	
Types of Rig	2.1
Standing Rigging	2.3
Mast Vibration	2.10
Sails	2.11
Folding Sails	2.11
Setting Sails	2.13
Halyard Clutches	2.20
SECTION 3 - STEERING SYSTEMS	
Rudders	3.1
Wheel Steering Systems	3.5
Hydraulic Steering	3.6
SECTION 4 - ENGINE SYSTEMS	
Engine Systems	4.1
Fuel Systems	4.1
Cooling Systems	4.3
Exhaust Systems	4.4
Engine Controls	4.5
Engine Instrumentation	4.6
Basic Engine Care	4.6
Turbochargers	4.10

## CONTENTS (Continued)

Title	Page
Stern Gear	4.12
<b>SECTION 5 - GAS SYSTEMS</b>	
Gas System	5.1
<b>SECTION 6 - WATER/WASTE SYSTEMS</b>	
Equipment Chart	6.1
Water Systems	6.2
Waste Systems	6.2
Brydon Marine Toilet	6.2
Brydon Toilet with Holding Tank	6.4
<b>SECTION 7 - ELECTRICAL SYSTEMS</b>	
Basic Electrical System	7.1
Batteries	7.2
Battery Isolation Switches	7.2
Switch Panels	7.4
Powercentre	7.4
IYS Switch Panel	7.8
<b>SECTION 8 - MAINTENANCE</b>	
Hull	8.1
Sails and Rigging	8.8
Steering Systems	8.9
Engine Systems	8.11
Gas Systems	8.15
Water/Waste Systems	8.15
Winterisation/Dewinterisation	8.15
Cleaning	8.19

## CONTENTS (Continued)

Title	Page
SECTION 9 – SPECIFICATIONS	
Konsort 29	9.1
Konsort Duo	9.2
Tempest 31	9.3
Fulmar 32	9.4
Storm 33	9.5
Storm 33 Cruising	9.5A
Riviera 35	9.5B
Seahawk 35	9.6
Falcon 35	9.7
Corsair II 36 – Sloop	9.8
Sealord 39 – Sloop	9.9
Oceanlord 40 – Sloop	9.10
SECTION 10 – WESTERLY YACHTS – PRE 1988	
Introduction	10.1
Equipment Charts	10.2
SECTION 11 – STEERING SYSTEMS – PRE 1988	
Whitlock Systems	11.1
SECTION 12 – ENGINE SYSTEMS – PRE 1988	
Engine Systems	12.1
Stern Gear	12.1
SECTION 13 – WATER/WASTE SYSTEMS – PRE 1988	
Lavac Marine Toilet	13.1
Lavac Toilet with Holding Tank	13.2
SL 400 Series Marine Toilet	13.5

## WESTERLY YACHT EQUIPMENT CHART

### CURRENT PRODUCTION YACHTS

<i>YACHT</i>	<i>KEEL</i>	<i>RIG</i>	<i>STEERING</i>	<i>ENGINE</i>	<i>RUDDER</i>	<i>BARLOW WINCH</i>
KONSORT	Fin/Twin	Sloop	Tiller	Volvo 2002	Transom	20c & 21c
KONSORT DUO	Twin	Sloop	Tiller/Hyd	Volvo 2003	Transom	21c
TEMPEST	Fin/Twin	Sloop	Tiller	Volvo 2002	Spade	24c & 18c
FULMAR	Fin	Sloop/3/4	Tiller/Wheel	Volvo 2002	Spade	6/16 & 6.5/34
STORM	Fin	Sloop	Tiller	Volvo 2002	Spade	25c & 27c
STORM CRUISING	Twin	Sloop	Tiller/Wheel	Volvo 2003	Spade	24c & 22c
RIVIERA	Fin/Twin	Sloop	Hydraulic	Volvo 2003	Spade	17c & 24c
SEAHAWK	Fin/Twin	Sloop	Edson Wheel	Volvo 2003	Spade	19c & 25c
FALCON	Fin/Twin	Sloop	Edson Wheel	Volvo 2003	Spade	19c & 25c
CORSAIR	Fin	Sloop	Edson Wheel	Volvo 2003/2003T	Spade	6.6/24 & 10.8/44.6
OCEANLORD	Fin	Sloop	Edson Wheel	Volvo 2003T	Spade	24c & 25c & 32c

## 1. HULL

### CONSTRUCTION

#### SKIN FITTINGS AND SEACOCKS

Skin Fitting Gate Valve  
Skin Fitting Sleeve Valve  
Skin Fitting Ball Valve

#### CATHODIC PROTECTION

Attachment  
Bonding  
Replacement

#### ANTIFOULING

## CONSTRUCTION

The main hull and deck is manufactured using Glass Reinforced Plastic (GRP). GRP matting and a polyester resin are laminated in moulds to produce the hull and deck shapes. The outer surfaces have a gelcoat layer approximately 1mm thick which provides a water resistant skin.

Three types of GRP are used: Unidirectional mat for high strength and reinforcing, woven roving for high strength and reinforcing, chopped strand Mat (CSM) for intricate mouldings.

PVC foam is used in deck and coach roof mouldings for strength. It is light in weight and does not absorb water.

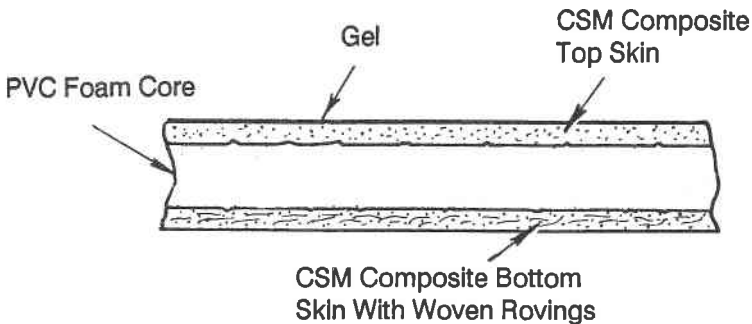

Fig. 1 - PVC Foam Sandwich

Plywood is used in high load areas such as stanchion bases. Aluminium plate is used at the mast heel plinth for high strength.

Hull stiffening is achieved using bulkheads and stringers. The stringers are usually polyurethane foam formers overlaid with GRP, on the inside of the hull and underside of the deck. Plywood can be used as an alternative.



The most important structural area is in the region of the keel attachment. This is heavily reinforced with polyurethane foam overlaid with GRP to withstand the tremendous forces exerted.

## SKIN FITTINGS AND SEACOCKS

Skin fittings are hull penetration points and must therefore be well sealed to prevent the ingress of water. This is achieved by moulding the fitting into the hull using GRP, or by using sealing rings or washers under the flanges of the fitting. The fittings are normally made from a corrosion resistant material such as bronze, stainless steel or plastic. They are either integrated with, or associated with, a seacock. The exception is where they are used to allow hull penetration for log or echo sounder transducers, etc.

The three types of seacock currently fitted to Westerly Yachts are:

### Skin Fitting Gate Valve

**Application:** Used for engine cooling with Volvo remote filter, sink drain outlet and cockpit drains.

**Operation:** Turn tap anti-clockwise to open and clockwise to close.

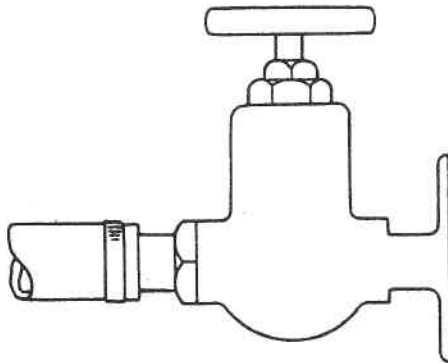

Fig. 2 - Gate Valve

## Skin Fitting Sleeve Valve

**Applications:** Toilet inlet and toilet outlet.

**Operation:** To open, turn lever to align with inlet/outlet hose.

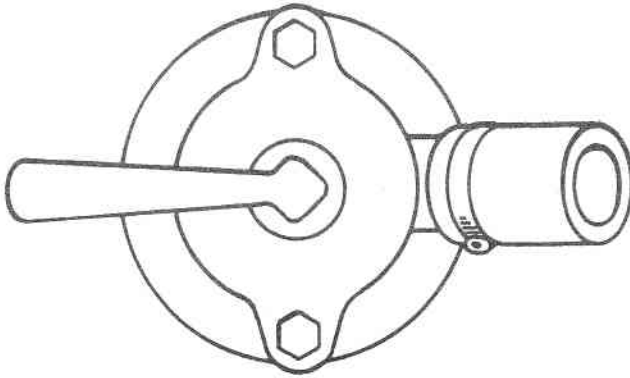

Fig. 3 - Open

To close, turn lever until at right angles to the inlet/outlet hose.

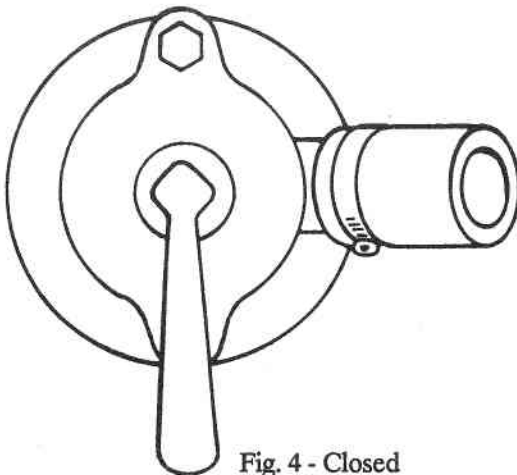

Fig. 4 - Closed

## Skin Fitting Ball Valve

**Applications:** Engine cooling systems, sink and cockpit drains.

**Operation:** To open, turn lever to align with inlet/outlet hose. To close, turn lever until at right angles to the inlet/outlet hose.

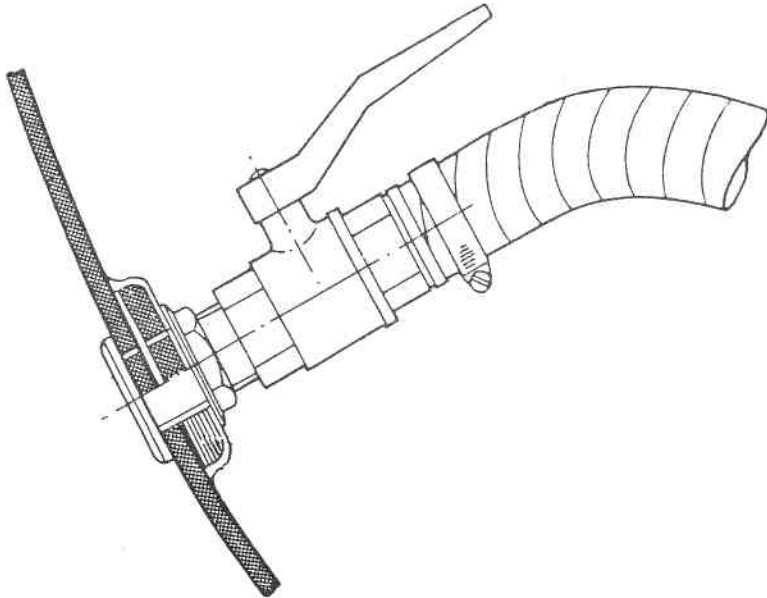

Fig. 5 - Ball Valve

## CATHODIC PROTECTION

Westerly yachts are fitted with hull mounted sacrificial anodes as these give the best results. These are usually mounted in the region of the engine compartment to keep the bonding cable run to a minimum.

## **Attachment**

This is achieved by using 3/8" studs permanently fixed to the hull to which the bonding cable is secured internally and the anode externally. The anode should be attached using nuts and locking washers.

## **Bonding**

The anode is bonded to the engine, stern tube bracket and engine cooling skin fitting. There is no requirement for the more remote skin fittings and seacocks, or the keel mounting bolts to be protected.

## **Replacement**

The anode should be replaced when it is approximately two-thirds eroded. If any doubt exists as to whether the anode will survive the season - change it! In the core of the anode is a galvanised steel strip which provides the attachment legs for the anode. The anode is removed by removing the two securing nuts and washers. It is recommended when replacing the anode, that the nuts, washers and backing sheet are also replaced. The original anode is manufactured by M. G. Duff, part number ZD77.

## **ANTIFOULING**

From July 1987, all yachts are antifouled with Blakes Tiger Tin Free Antifouling.

## 2. SAILS AND RIGGING

2

### TYPES OF RIG

#### STANDING RIGGING

- Shroud Plates
- Maintenance Checks
- Rig Adjustment
- Ajustment of Fractional Rig

#### MAST VIBRATION

- Theory
- Actions to Minimise Effect

#### SAILS

- Resinated Sailcloth
- Supercruise

#### FOLDING SAILS

- Mainsail
- Headsails
- Bagging
- Folding

#### SETTING SAILS

- Hoisting
- Sheeting & Trimming
- Kicking Strap
- Mainsail Reefing
- Spinnakers

## TYPES OF RIG

Yachts are either Sloop or Ketch rigged. Most yachts of under 31 feet LOA are Sloop rigged. (Fig. 1).

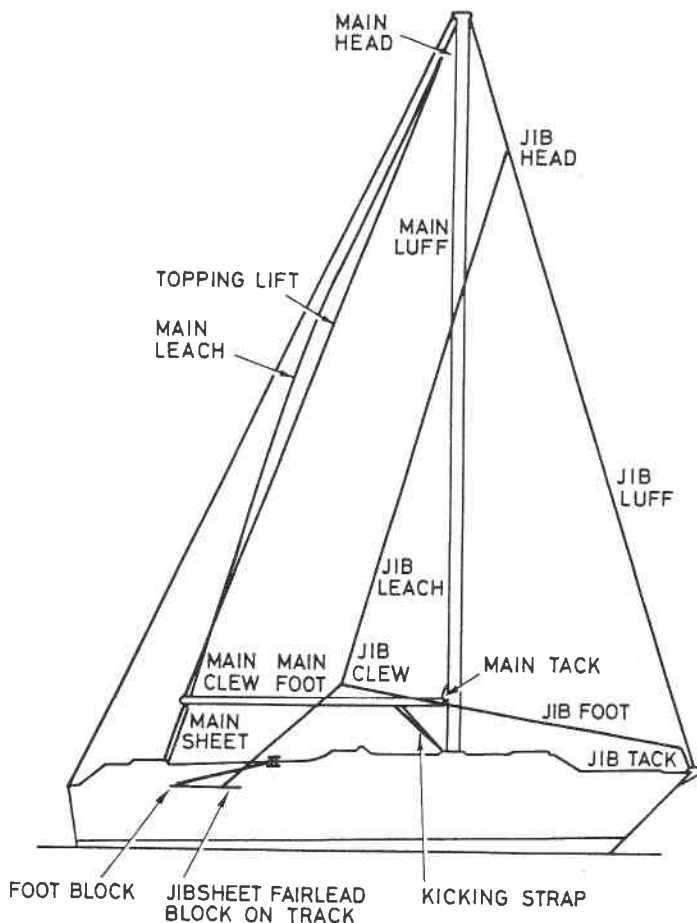

Fig. 1 - Sloop Rig

The difference between Sloop and Ketch rigged yachts is the addition of a mizzen mast.

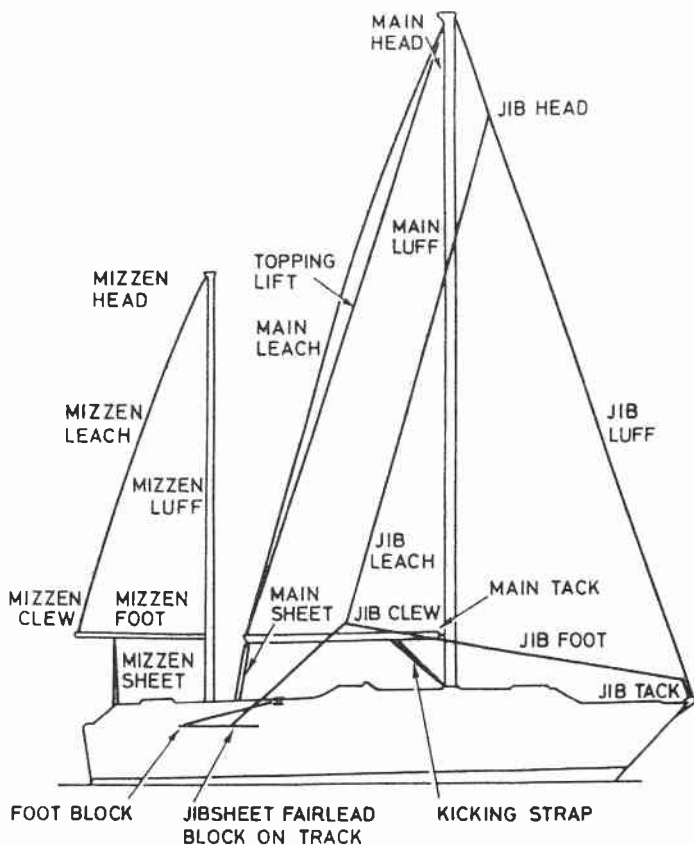

Fig. 2 - Ketch Rig

## STANDING RIGGING

The standing rigging is the only support for the mast(s). It is made from stainless steel and has a finite life, therefore it is vital that it is adjusted and maintained correctly. Fig. 3 illustrates the basic standing rigging for a Sloop.

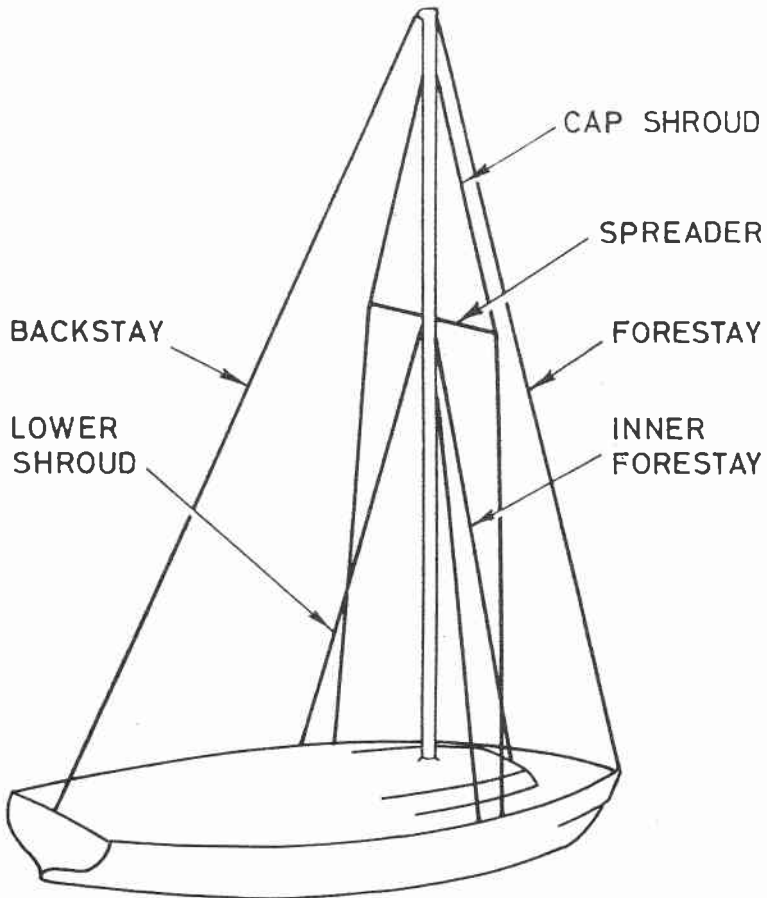

Fig. 3 - Sloop



The Ketch rig has additional standing rigging for the mizzen mast (Fig. 4).

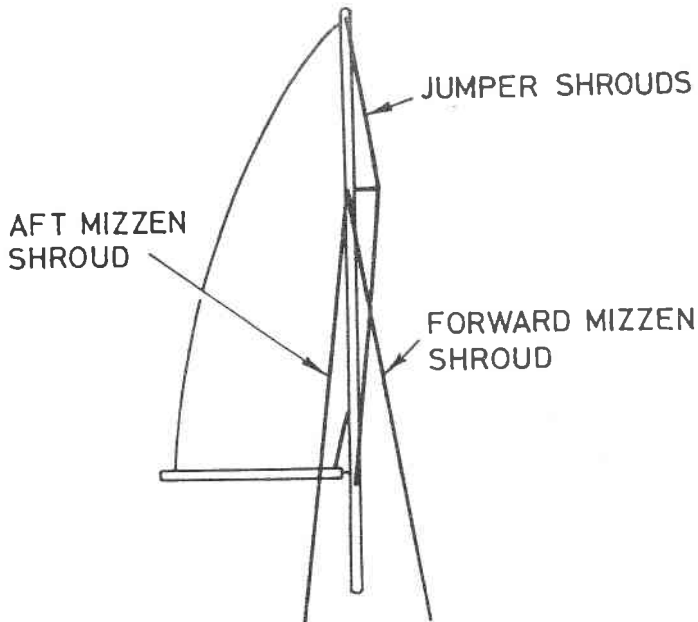

Fig. 4 - Ketch Rig

### Shroud Plates

The standing rigging is attached to Shroud Plates, commonly called Chain Plates, located either side of the mast at deck level. These are reinforced to withstand the tremendous pressure exerted by the sails. (Fig. 5 shows the strengthening used).

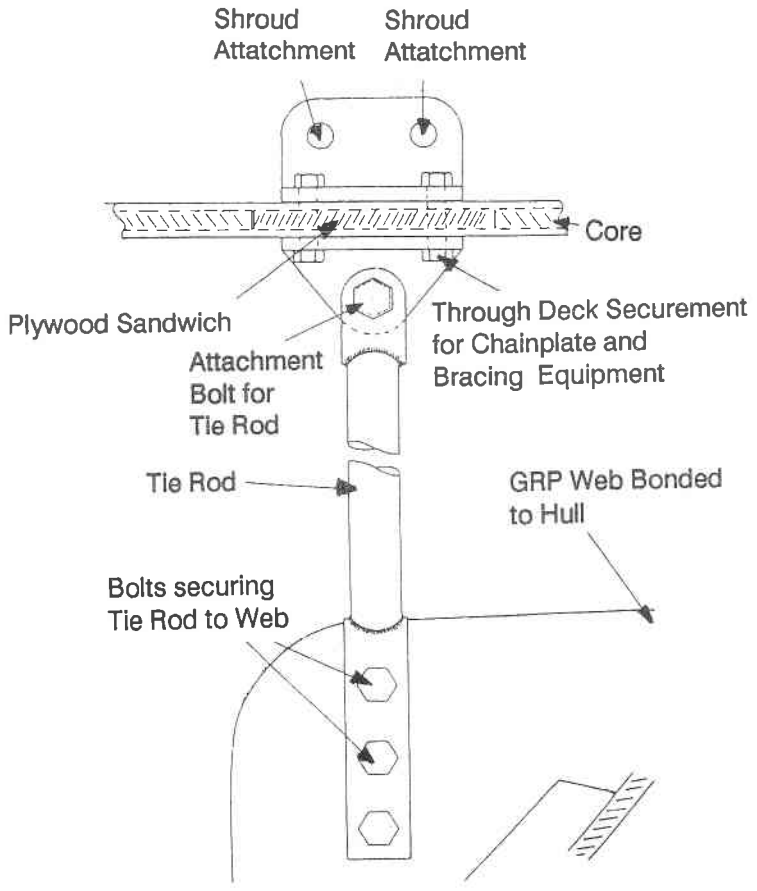

Fig. 5 - Shroud Plate

## Maintenance Checks

Maintenance should be carried out regularly during the season when the yacht is in commission and before any long voyage. Commissioning and Winterisation checks are covered in the Winterisation/Dewinterisation section of this manual.

- 1 Examine all steel wire rope for signs of corrosion, wear and damage.
- 2 Examine all terminations for signs of wear or damage. Pay particular attention at all split pins.

**Note: Split pins should be a good fit through hole and should not be undersized.**

- 3 Examine all bottle screws for signs of fatigue wear or damage and ensure they are 'in safety', ie. the inner threads are visible through both safety holes. Where bottle screws are covered with tape or plastic tubing, remove it to enable examination.
- 4 Ensure the ends of the spreader bar are protected to prevent sail chafing.
- 5 Ensure the rig is correctly adjusted. If you are in any doubt, you should consult the mast manufacturers or a rigging specialist.

## Rig Adjustment

Most Westerly yachts have a Masthead Rig, adjustment is as follows:

- 1 Set up the mast with all rigging slack (see Fig. 6).
- 2 Tension the cap shrouds.
- 3 Tension the forestay and backstay.

- 4 Harden down on the cap shrouds.

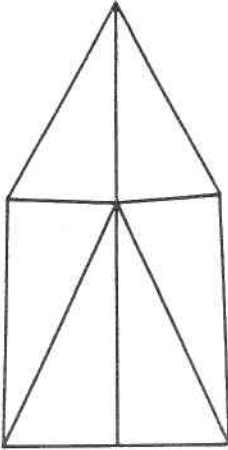

Fig. 6 - Slack

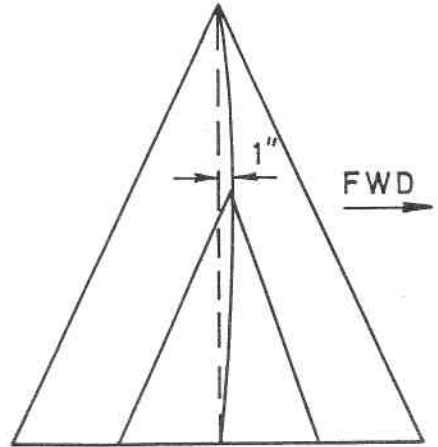

Fig. 7 - Bowed

- 5 Tension inner forestay until mast bows forward 2" at the spreaders.
- 6 Tension the aft lower shrouds equally to reduce the bow to 1" (see Fig. 7).
- 7 Check the rig whilst sailing. The tension in the mainsail will straighten the mast.
- 8 Whilst sailing, check the sideways bend. If the mast leans to windward, tighten the cap shrouds (see Fig. 8). If the mast leans to leeward, tighten the aft lower shrouds (see Fig. 9), then check the fore and aft bend. If the mast is bent aft, into the mainsail, tighten the inner forestay.

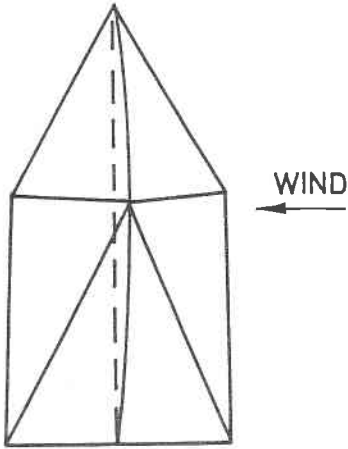

Fig. 8 - Windward

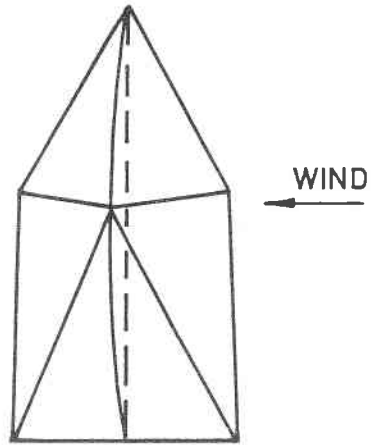

Fig. 9 - Leeward

9 Tensioning the backstay will result in the mast bowing aft (see Figs. 10 & 11).

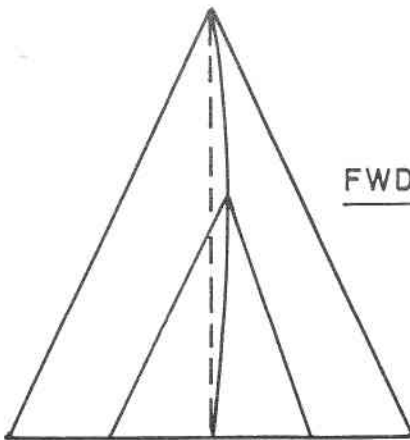

Fig. 10 - Bowed

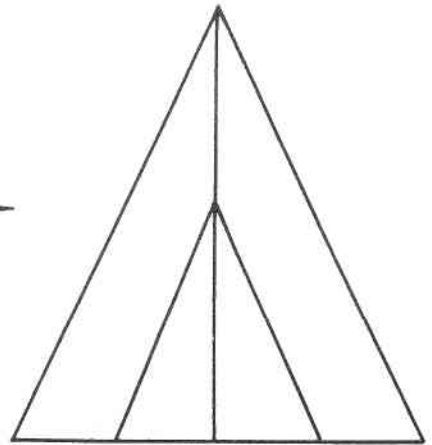

Fig. 11 - Straight

### Adjustment of Fractional (3/4) Rig

Some Westerly yachts have a Fractional Rig. It is also known as a 3/4 Rig. Adjustment for this type of rig is as follows:

- 1 Set up the mast with all rigging slack.
- 2 Tension forestay and upper shrouds (leaving the backstay slack) until the mast has a 1" forward bend at the spreaders (see Fig. 12).
- 3 Tension lower shrouds until mast is straight.

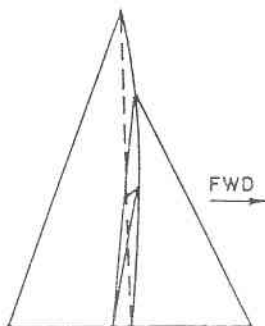

Fig. 12 - 3/4 Rig

- 4 Check the rig whilst sailing. The mast should remain straight. Check the mast for sideways bend. If the top of the mast leans to leeward, loosen the lower shrouds (see Fig. 13). If the spreaders lean to leeward, tighten the lower shrouds (see Fig. 14).

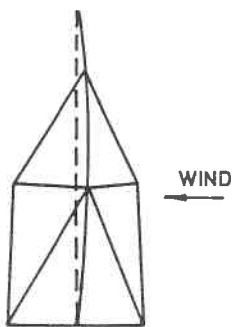

Fig. 13 - Mast

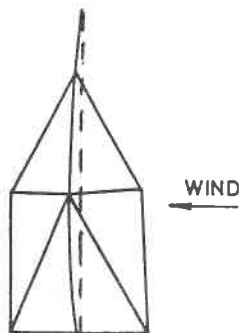

Fig. 14 - Spreaders

**Notes: The backstay is used only for bending the top of the mast when sailing to windward.**

**When reaching and running, the tension in the backstay must be reduced to keep the top section of the mast straight.**

**The upper shrouds should be kept tight.**

## **Riviera 35 mast rigging procedure**

**Mast: Kemp Furlin' 213/104**

**Designed Rake: 1 mast section aft (213mm)**

- 1 Adjust forestay and backstay to achieve designed aft rake.**
- 2 Lightly tension babystay.**
- 3 Tension cap shrouds and intermediates checking continuously for any aft bend.**

**Note: If tensioning the shrouds causes the mast to bend aft, note the degree of bend and the circumstances in which it occurred. This information will be needed by the mast manufacturer.**

- 4 a) If the shrouds can be tensioned without bending the mast, the aft lower shrouds can be tensioned and all rigging checked.**
- b) If the mast does bend, and it was induced by the intermediate shrouds, partially slacken the shrouds and tension the babystay to pull the mast forward. Then retension the shrouds and re-check the mast.**
- c) If the bend was induced by the cap shrouds adjust the forestay/backstay in conjunction with the babystay to remove bend.**

**Notes: Tension in the cap shrouds and Intermediates should put the mast into compression ONLY and the resulting aft bend is a fault of the mast spreader positions and/or heel fitting pivot position relative to the neutral axis of the mast.**

**Problems encountered during rigging should be reported so that the manufacturers can be informed.**

**During rigging also check for any closing of the sail slot in the aft face of the mast, particularly in the vicinity of the spreaders.**

## **Working Aloft**

Boats fitted with Kemp Inmast furling systems should under no circumstances use halyards fitted with removable halyard tails, specifically the mainsail and genoa halyard tails, for winching people aloft, or for work with the bosun's chair. Removable halyard tails are not designed to be load bearing and must never be used for working aloft. Spars are supplied with spare mainsail halyards, these halyards only should be used with the bosun's chair.

## **MAST VIBRATION**

Vibration appears at moderate wind speeds, occurring in an athwartships wind direction. The vibration is caused by eddy currents on the leeward side of the mast, the frequency depending on wind speed, mast section and size.

When the natural flexing frequency of the mast coincides with the oscillation frequency, resonance occurs and the amplitude rapidly increases and causes vibration. The amplitude is dependant on the mast section, size and any aerodynamic damping. The vibration is known as the 'Karman' effect.

### **Actions to Minimise Effect**

- 1 Add additional inner wire forestay.
- 2 Increase tension on the stays to decrease the natural frequency of the mast.
- 3 Use a 'Vortex Break'. This is a 4" strip of 9oz sailcloth, hoisted up the mast groove on the leeward side. This prevents the vortex turbulence from causing vibration.



- 4 Internal mast halyards can magnify the noise of the vibration. This can be reduced by using internal polyurethane foam 'cushions'.

## **SAILS**

Your Westerly yacht is supplied with Ratsey and Lapthorn sails which, if treated with care and maintained correctly, will give many seasons good service. Your sails will be made from either Vectis resinated sailcloth or Supercruise.

### **Resinated Sailcloth**

This is the conventional sailcloth used and contains resin fillers. These sails must be folded to prevent the resin filler from breaking up and causing permanent creases. These creases distort the sail shape and make them virtually impossible to set.

### **Supercruise**

Supercruise does not contain any fillers, therefore stows easily and remains crease-free. It should however, still be treated with care.

### **WARNING: Do not smoke when working with sails.**

Cigarette burns cause expensive damage to sails. It is strongly recommended that smoking is not allowed by any member of the crew when handling sails.

## **FOLDING SAILS**

### **Mainsail**

One of the easiest methods of folding the mainsail is with it still on the boom:

- 1 Tighten topping lift to support boom.

- 2 Lower the sail fully.
- 3 Ensure the coachroof is closed.
- 4 Ease the tension in the foot of the sail by releasing the clew outhaul.
- 5 Remove the battens to minimise stretch and chafing in the batten pockets.
- 6 Stand close to the mast, on the opposite side of the boom to the pile of mainsail.
- 7 With an assistant at the leach, take hold of the sail about twelve inches from the boom, pull up together and lay the sail halfway over the boom. The bottom of the hanging fold should be approximately level with the bottom of the boom.
- 8 Take a further twelve inches of sail and fold back over the boom in the opposite direction.
- 9 Continue this 'layering' action until the entire sail is layed over the boom.
- 10 Secure the sail to the boom using sail ties.
- 11 The halyard can either be removed and stowed or left attached to the head of the sail. If left on the sail, secure to the boom by passing a sail tie through the head of the sail and then tension the halyard.
- 12 If the sail is to remain folded for more than a few hours, put the sail cover on to prevent damage from ultraviolet light or other source.

## **Headsails**

If your yacht is not fitted with a furling headsail, the headsail must be removed and bagged when not in use. Depending on the type of sail, it can be folded or 'bagged' in the sailbag.

### **Bagging**

- 1 Put the head of the sail into the sailbag first.
- 2 Work the luff and the leach in together, also the body of the sail.
- 3 Leave the tack and clew until last and pass the sailbag neck cord through both tack and clew before drawing tight. This method proves its worth in adverse conditions, enabling the tack to be connected to the stemhead and the sheets to be fitted to the clew before the sail is released from the sailbag. The sheets can then be run back and secured without being 'snatched' by the sail. The sail can also be hanked to the fore stay, one hank at a time, until only the head is left to be attached to the halyard.

### **Folding**

- 1 Lay the headsail out flat in a convenient position, a pontoon or jetty is ideal.
- 2 The sail should then be folded following the steps illustrated in Fig. 15.

## **SETTING SAILS**

No yacht will sail well if the sails are badly set. The few points which follow are included to assist in setting sails correctly.

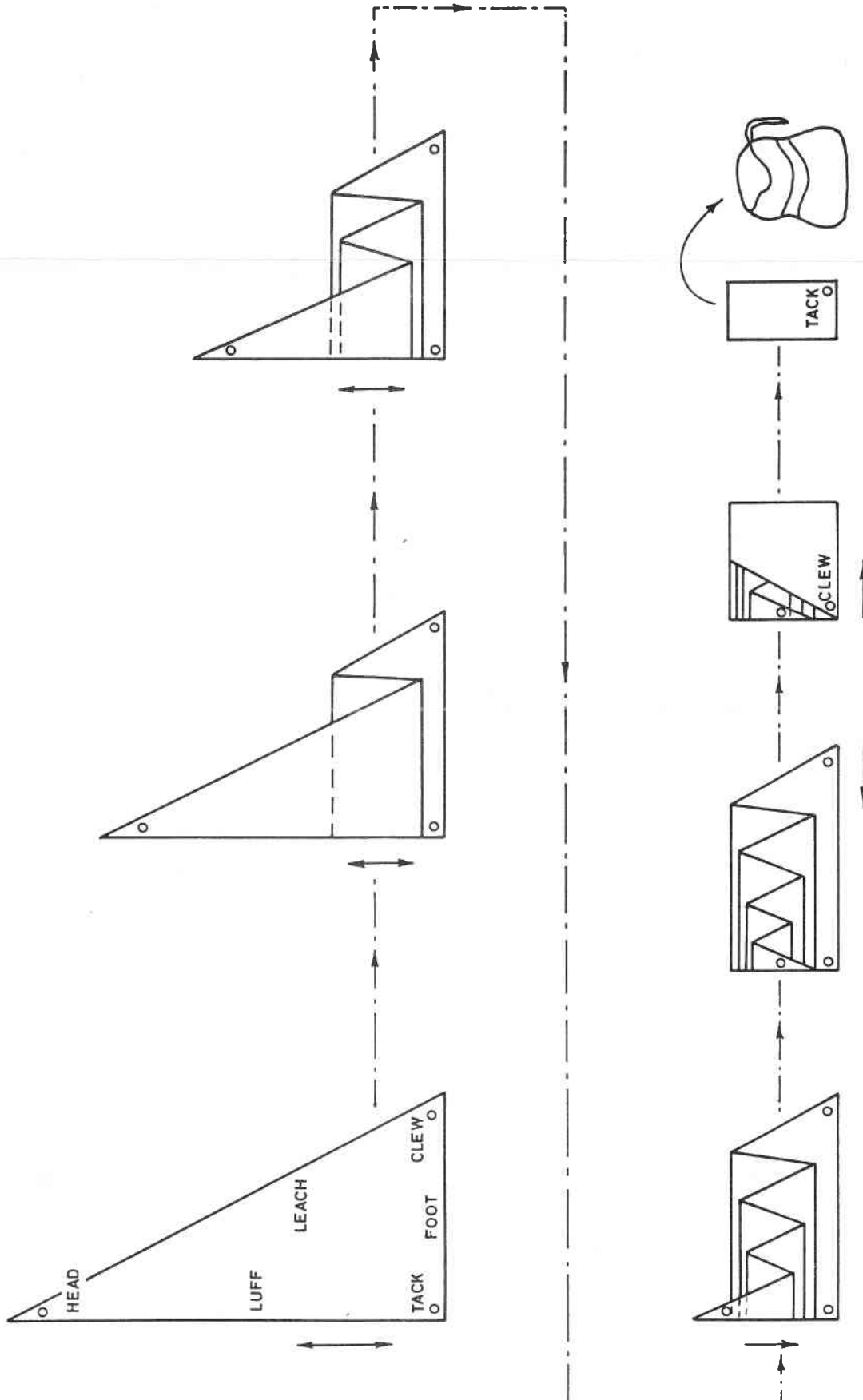

Fig.15-Folding a Headsail

## **Hoisting**

Whilst this is a straight forward procedure, the amount of tension in the halyard depends on wind conditions. All modern sails respond well to differing tensions. Hoist the mainsail fully ensuring that there are no wrinkles in the luff, and on a headsail, that the luff does not curve away from the forestay between the hanks. Creases in a sail are the first sign of incorrect tension and depending on their position, they indicate whether there is too much or too little tension in the halyard. It is recommended that you deliberately slacken and overtension the sails on your yacht in different wind conditions to learn their peculiar characteristics. Some owners mark their halyards so that the correct tension can be applied each time.

## **Sheeting and Trimming**

The basic rule of sail sheeting is "Let it out 'til it flaps, pull it in 'til it stops."

The most common fault is sheeting in too hard. This is best explained in books specifically written for that purpose. It is recommended that every yacht's library has one.

## **Kicking Strap**

This controls the amount of twist in the mainsail and also ensures that the boom does not 'kick up'. The kicking strap must always be tensioned, the only exception being when the mainsail is sheeted in hard. The easiest way to tension the kicking strap to the optimum position is by using the top batten as a guide. This should be parallel to the boom. If it lies to leeward, tighten the kicking strap, if it lies to windward, loosen it.

## **Mainsail Reefing**

All current production yachts are fitted with slab reefing. Fig. 16 shows the slab reefing arrangement where reefing guides are not fitted. Yachts manufactured prior to 1978 may be fitted with Proctor roller reefing systems. If information is required, it is suggested that Proctor Masts Ltd be contacted.

## **Spinnakers**

Four basic configurations of spinnaker and cruising chutes are shown in Fig. 17. These are:

**CROSS CUT** - Usual type used for running and reaching.

**RADIAL HEAD** - Similar to cross cut but with improved head shape for better strength and setting.

**TRI RADIAL** - Flatter type used for reaching.

**CRUISING CHUTE** - Cross between genoa and spinnaker but unsuitable for fine reaching. Very versatile and easy to rig, can be used without a pole.

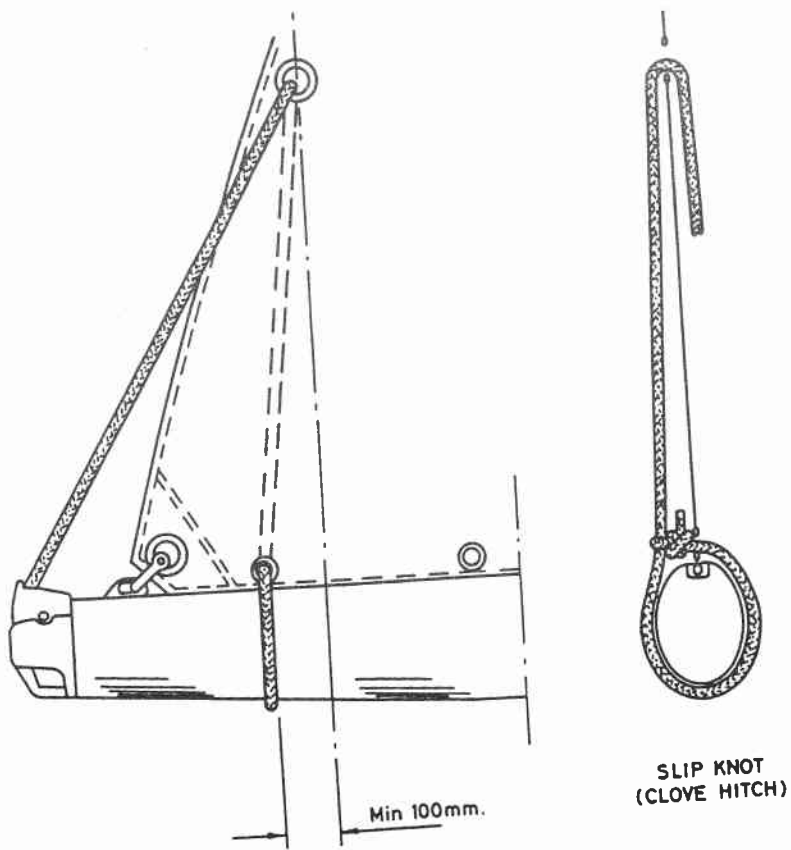
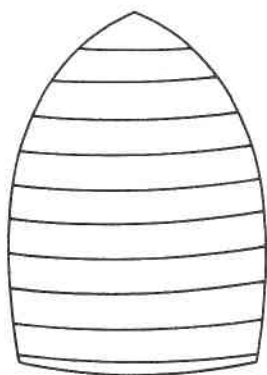
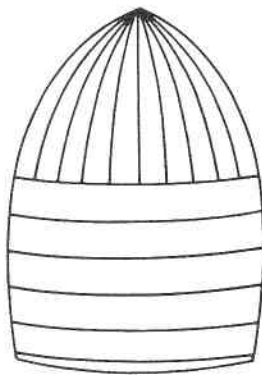

Fig. 16 - Mainsail Reefing



CROSS CUT



RADIAL HEAD

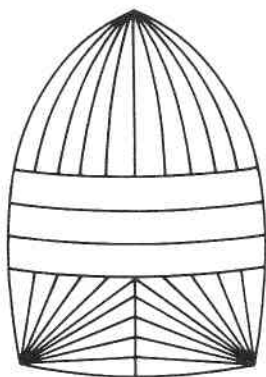

TRI RADIAL

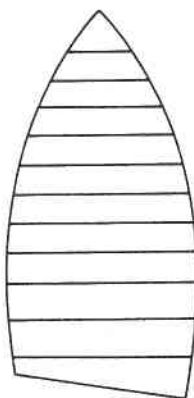

CRUISING CHUTE

Fig. 17 - Spinnakers



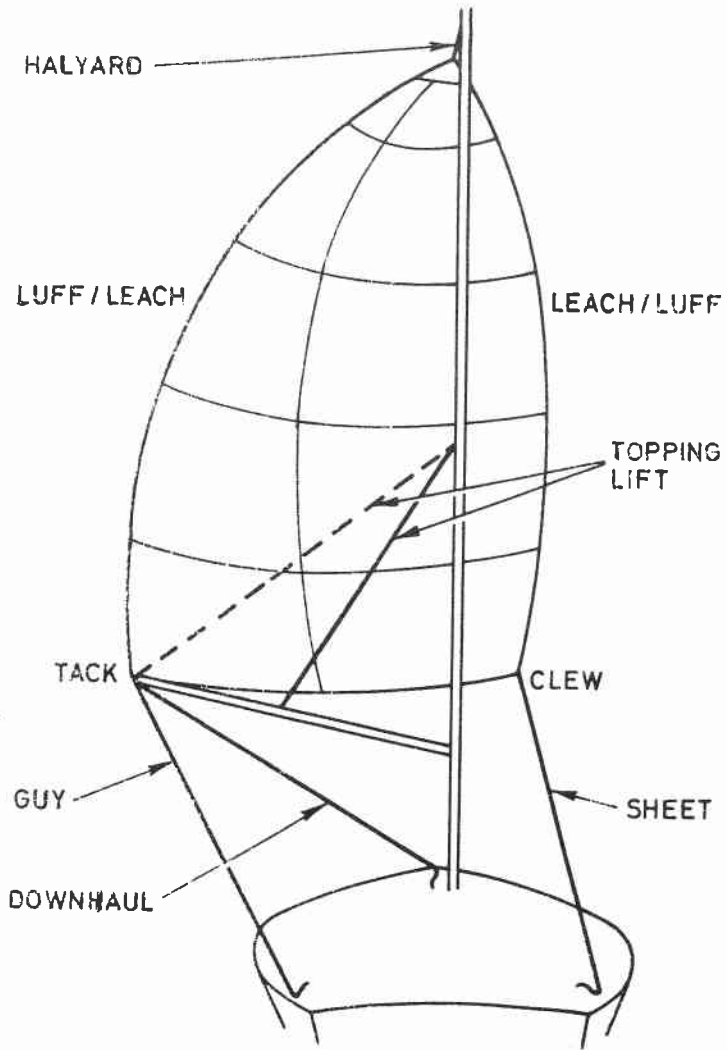

Fig. 18 - Typical Spinnaker Rigging Arrangement

## HALYARD CLUTCHES

### Winching In: Clutch Action

The clutches are designed to hold loaded rope automatically: the halyard can be winched through the clutch with the handle closed and then the rope tail can be safely removed from the winch drum without touching the clutch. It is normal for rope to travel out through the clutch by approximately 25 mm as the cam rotates to lock the rope.

Should the release handle lift as the rope is being tensioned, this should be closed down before the tail is removed from the winch.

### For Extra Tension

Where halyard tension is most critical (Genoa and Main) you have the option of a very effective **MANUAL LOCKDOWN** facility. In heavier conditions a tight luff is essential and requires far more than normal loading of the halyard. To achieve this, the handle is lifted to its vertical position and then firmly re-locked onto the loaded rope. This reduces rope travel to 5-10mm.

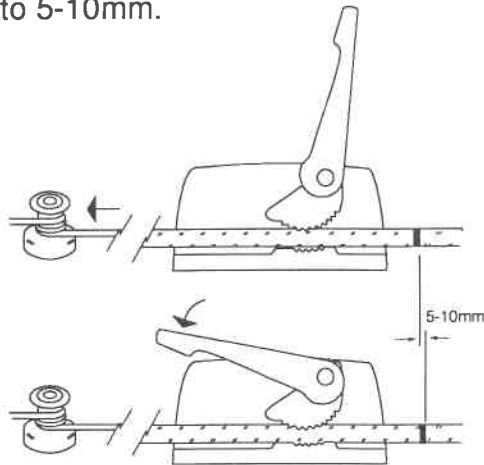

It is important to mark the halyard as an aid to maintain the correct setting. This immediately indicates any loss of tension that might effect windward performance.

## **New Rope**

New halyards are slippery. If the halyard slips when in the "CLUTCH" mode, use the MANUAL LOCK-DOWN facility until the halyard has been worked in.

## **Release**

In normal wind conditions the load can be effortlessly released simply by lifting the handle without using the winch. In heavier weather release is still possible this way - but for reasons of safety and rope care, rope should be re-tensioned on the winch drum before releasing the clutch. For safe release, the handle should be moved into its fully-open position so that the cam is lifted well clear of the moving rope.

After release the handle should be moved into its fully-open position so that the cam is lifted well clear of the moving rope. After release the handle should be closed once more - not left open to get in the way of the rigging or crew.

## **Warranty**

In the event that this product fails to perform satisfactorily for any reason, a rapid help and advice service is operated by the manufacturer. Each clutch unit is covered by a two year warranty and any claim under this warranty should be made directly to Spinlock at the following address:

SPINLOCK CUSTOMER SERVICE  
OFFSHORE INSTRUMENTS LTD.  
41 BIRMINGHAM ROAD  
COWES  
ISLE OF WIGHT  
PO31 7BH  
UNITED KINGDOM

TELEPHONE: (0) 983 295555

## **3. STEERING SYSTEMS**

### **RUDDERS**

Transom Hung Rudder

Spade Hung Rudder

### **WHEEL STEERING SYSTEMS**

Edson Pedestal Steering

Maintenance

### **HYDRAULIC STEERING**

Use with Autopilot

Hydraulic Fluid

Fault Finding

Further Information

## RUDDERS

Two main types of rudder are fitted, transom hung and spade hung.

### Transom Hung Rudder

This type of rudder is attached to the yacht by support brackets mounted on the transom as shown in Figs. 1 & 2.

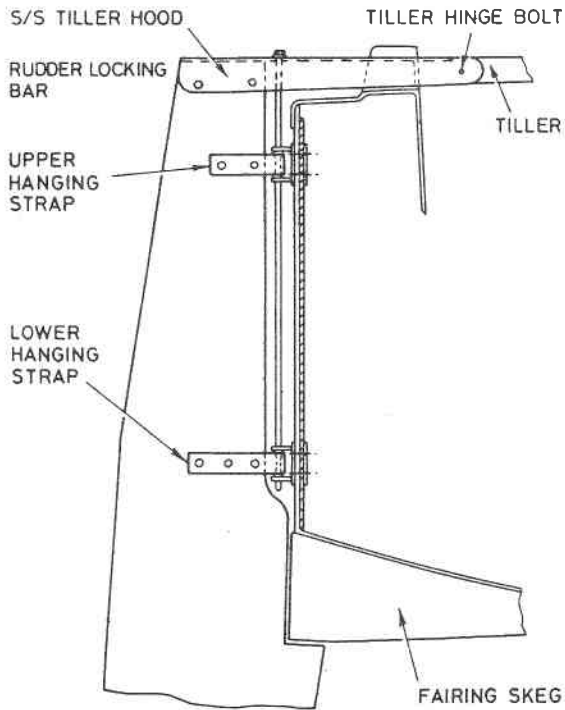

Fig. 1 - Transom Hung Rudder

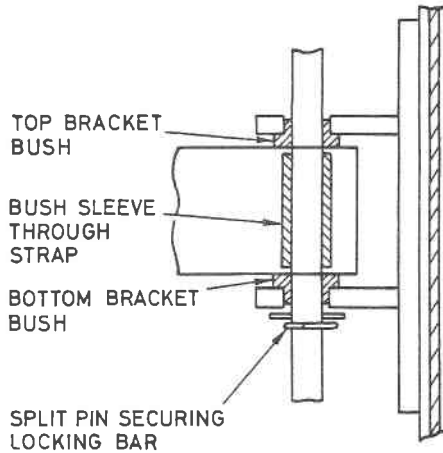
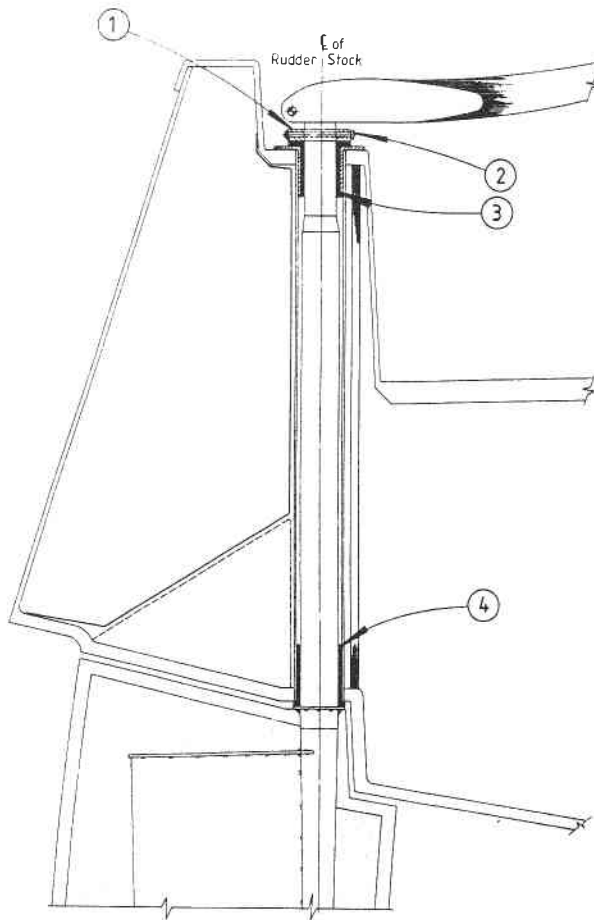

Fig. 2 - Bush Arrangement

## Spade Hung Rudder

This is the standard rudder fitted to Westerly yachts, consisting of a long stainless steel stock passing through the deck and hull. A stainless steel web is welded to the stock and a GRP rudder is moulded over the stock and web. It can be operated by either a tiller or wheel. For wheel operation, a steering quadrant is fitted to the stock within the hull area. An autopilot operating arm is normally also fitted. Figs. 3 & 4 show typical arrangements for tiller and wheel applications. The bearings currently fitted are made from Perplas 1000 which will not rot or corrode and is self-lubricating, thereby reducing maintenance. These bearings should however be checked when the yacht is lifted for winterisation.



- 1 - S/S Collar
- 2 - S/S Bolt
- 3 - Top Bush
- 4 - Bottom Bush

Fig. 3 - Tiller Steering Arrangement

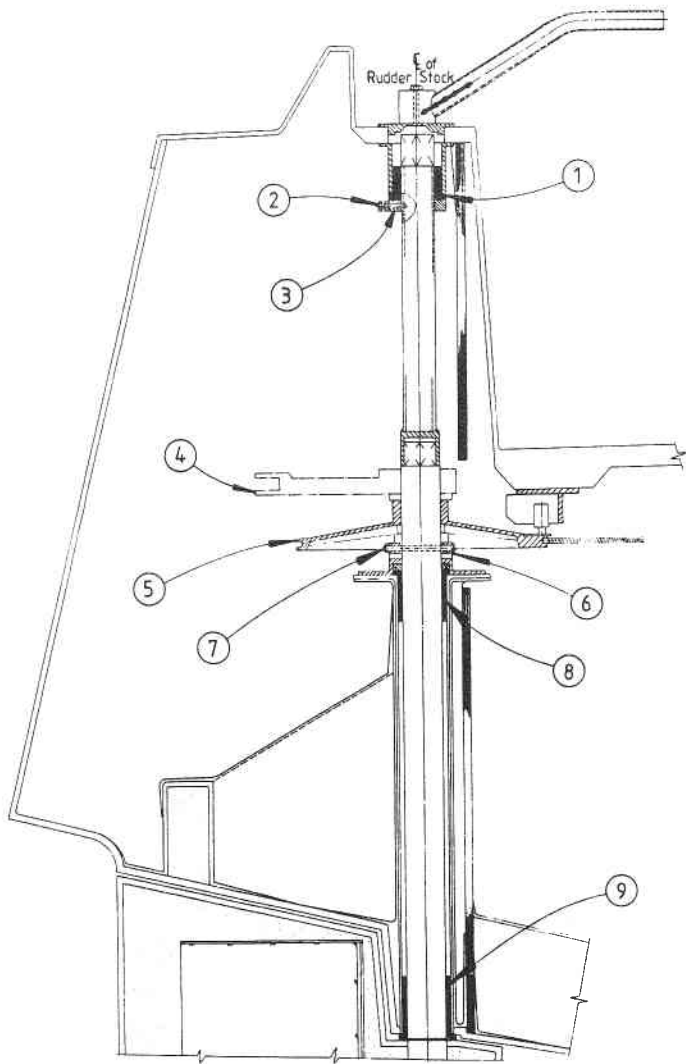

- |                   |                       |
|-------------------|-----------------------|
| 1 - Top Bush      | 6 - S/S Collar        |
| 2 - S/S Bolt      | 7 - S/S Bolt          |
| 3 - S/S Collar    | 8 - Intermediate Bush |
| 4 - Autopilot Arm | 9 - Bottom Bush       |
| 5 - Quadrant      |                       |

Fig. 4 - Wheel Steering Arrangement



## WHEEL STEERING SYSTEMS

The type currently fitted is manufactured by Edson. Some yachts were fitted with Whitlock systems and information on these can be found in the Steering Systems section for Old Models.

### Edson Pedestal Steering

Currently fitted is the double bowden cable type (Fig. 5). The cables are adjusted and tensioned at the quadrant. All cables should be checked and adjusted if necessary after the first 10 hours of use, and at regular intervals throughout the season.

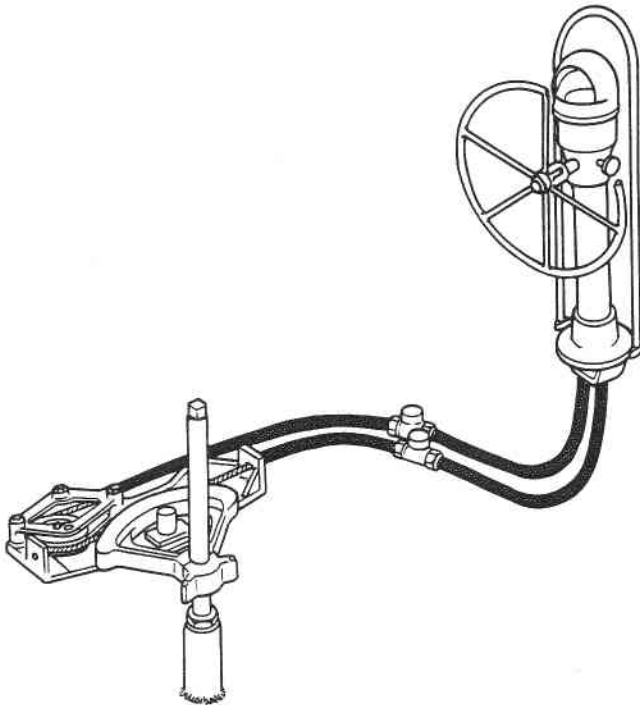

Fig. 5 - Edson Steering System

Spare parts lists and repair information can be obtained from Westerly Yachts Limited or from:

Navigair Limited, Hamble River Boat Yard, 296 Bridge Road, Swanwick, Hants. SO3 7EB

or

The Edson Corporation, 460 Industrial Park Road, New Bedford, Mass. 02745

## **Maintenance**

Steering system maintenance is covered in the Maintenance Section of this manual.

## **HYDRAULIC STEERING**

The Konsort Duo has a transom hung rudder and tiller. It also features a Teleflex hydraulic steering system (Fig. 6). The helm wheel operates a hydraulic pump which actuates a hull mounted double acting cylinder, connected to the rudder between the hanging straps. A locking valve allows the system to be 'locked' in any position.

The system should be checked after the first 10 hours of use, and periodically throughout the season, to make sure all joints are free from leaks and the oil level is correct.

### **Use with Autopilot**

Any autopilot designed for hydraulic steering systems may be used, providing it is compatible with the hydraulic fluid specified for the Teleflex system. It is recommended that shut off valves are fitted to simplify trouble shooting and servicing.

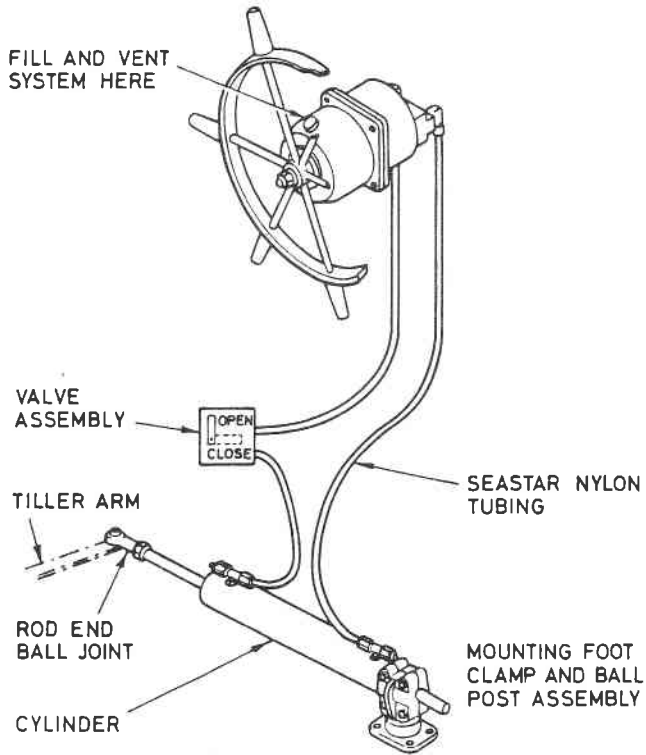

Fig. 6 - Hydraulic Steering System

### Hydraulic Fluid

Use only the correct fluid. (Shell Tellus 10 or Exxon Unavis J-13). In an emergency, automatic transmission fluid such as Dexron II can be used. NEVER USE BRAKE FLUID. The system is filled at the pump unit (Fig. 7).

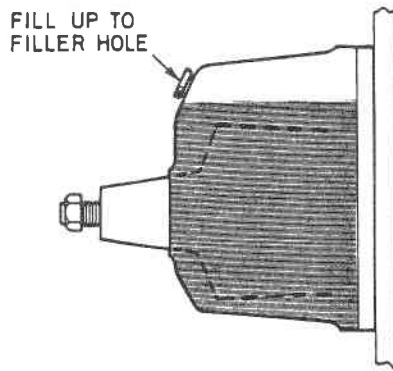

Fig. 7 - Pump Unit Oil Level

### **Fault Finding**

A fault finding chart is provided in the Maintenance Section of this manual

### **Further Information**

Further information on the system can be found in the Syllen Pump Manual and the Seastar Ram Manual supplied with the Konsort Duo.

## 4. ENGINE SYSTEMS

### ENGINE SYSTEMS

#### FUEL SYSTEMS

Fuel Tanks  
Fuel Stopcock  
Fuel Filter  
Return Pipe  
Fuel Contents

#### COOLING SYSTEMS

Seawater Cooled Engines  
Freshwater Cooled Engines  
Water Filter

#### EXHAUST SYSTEMS

#### ENGINE CONTROLS

Engine Stop Mechanism

#### ENGINE INSTRUMENTATION

#### BASIC ENGINE CARE

Maintenance  
Tools  
Maintenance Products

#### TURBOCHARGERS

Operating Instructions  
Maintenance

## 4. ENGINE SYSTEMS (Continued)

### STERN GEAR

Cutlass Bearing

Calcium Deposits

Shaft Seal Venting

Venting Procedure

Lubrication

## ENGINE SYSTEMS

The engines fitted to 1987 production yachts are Volvo 2000 series:

**VOLVO 2002** - Griffon Club, Merlin, Konsort, Fulmar, Storm, Tempest

**VOLVO 2003** - Konsort Duo, Seahawk, Falcon, Corsair

**VOLVO 2003T** - Corsair, Oceanlord, Sealord

Each yacht is supplied with the relevant manufacturers literature for its engine. The following information is therefore of a general, rather than a specific, nature and is superseded by any specific information given in the manufacturers literature.

## FUEL SYSTEMS

The basic fuel system is illustrated in Fig. 1.

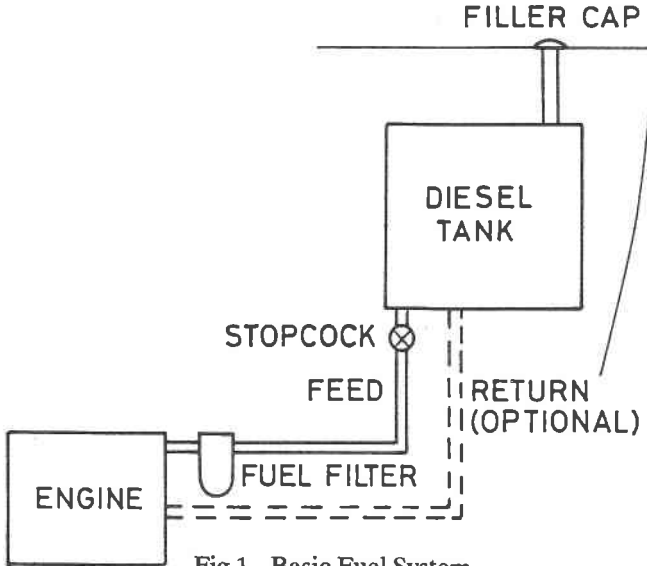

Fig 1 - Basic Fuel System

## **Fuel Tanks**

All yachts have heavy gauge mild steel fuel tanks, externally treated with a corrosion resistant paint finish. Where tanks are exposed to damage by stowed equipment, a regular check should be made to ensure there is no damage to the external finish, causing rust spots to develop.

## **Fuel Stopcock**

Unless the fuel system is undergoing repairs or maintenance, it is normal to leave the fuel stopcock on. If the engine is run with the stopcock turned off, an airlock can be caused which will necessitate bleeding the system.

## **Fuel Filter**

The bulkhead fuel filter should be checked regularly for water and drained or cleaned as necessary.

## **Return Pipe**

On some engine installations there may be a return pipe to the fuel tank from the engine fuel pump.

## **Fuel Contents**

Fuel tank contents are normally determined using a dipstick, but some yachts may be fitted with fuel gauges.

## **Notes:**

- 1 Keep the fuel tank full whenever possible as this prevents condensation forming in the tank.**
- 2 Avoid spillage of fuel on the deck. Diesel on a deck can be dangerous, it also attracts dirt.**



## COOLING SYSTEMS

The basic cooling system is illustrated in Fig. 2.

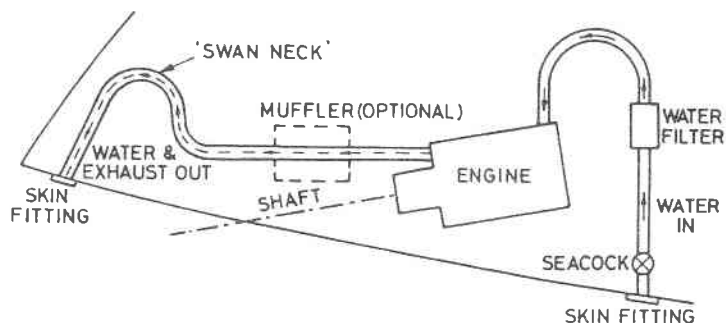

Fig. 2 - Basic Cooling & Exhaust System

Seawater is drawn into the system by the engine impellor, entering the yacht through a skin fitting. It passes through a seacock and a filter, before passing through the engine and out through the exhaust system. Its passage through the engine depends on the type of cooling system.

### Seawater Cooled Engines

In this type of engine, the seawater circulates through galleries in the engine and gearbox before being injected into the exhaust pipe for discharge.

## **Freshwater Cooled Engines**

This type of system uses freshwater which circulates through the engine and a heat exchanger in a closed circuit. Seawater passes through the heat exchanger, where the heat is transferred to it from the closed circuit freshwater system. The heated seawater is then injected into the exhaust system for discharge. This type of engine runs at a slightly higher temperature.

### **Water Filter**

This basic strainer is a bulkhead mounted black cylinder approximately 5" in diameter. For inspection, the cap unscrews anti-clockwise allowing access to the coarse wire mesh filter.

#### **Notes:**

- 1 Ensure cap is not cross-threaded when replaced.**
- 2 Ensure cap is screwed down tightly to prevent air ingress. This can cause damage to the impellor and the engine if overheating occurs.**

## **EXHAUST SYSTEMS**

The injection of the cooling water reduces the temperature of the exhaust gasses allowing them to be discharged, through reinforced rubber tubing, to the bronze exhaust skin fitting. The exhaust tube has a 'swan neck' to reduce the possibility of seawater being forced into the exhaust and into the cylinders, causing damage to the engine. This problem can further be avoided in two ways:

- 1 Close the inlet stopcock several seconds before stopping the engine.**
- 2 After three or four attempts to start a stubborn engine, close the inlet stopcock until the engine starts.**

## WARNINGS:

- 1 DO NOT CRANK THE ENGINE OVER USING THE BATTERY WITHOUT CLOSING THE STOPCOCK. YOU MAY CREATE A HYDRAULIC LOCK AND CAUSE MAJOR DAMAGE TO THE ENGINE.
- 2 WHEN STARTING AN ENGINE, CHECK THAT WATER IS BEING EJECTED THROUGH THE EXHAUST WITHIN 20 SECONDS. IF NOT, SWITCH OFF AND INVESTIGATE. FIRST CHECK THAT THE INLET STOPCOCK IS OPEN.

## ENGINE CONTROLS

Current yachts are fitted with the single lever 'Volvo TX' type throttle and gear change lever.

N = Neutral

F = Forward Gear

R = Reverse Gear

T = Throttle Increase

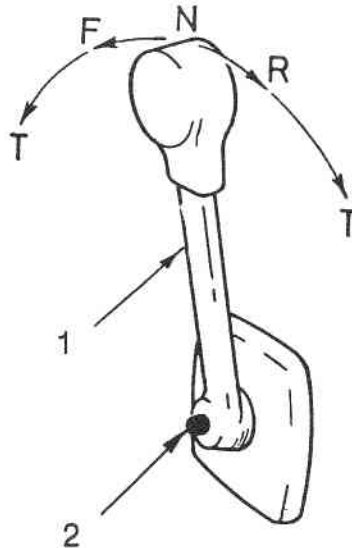

Fig 3 - Volvo TX Lever

Moving the lever to F or R, increases the engine revs and selects the appropriate gear. Further movement of the lever increases the engine revs until they reach maximum. To increase engine revs without selecting a gear, with the lever in neutral, press and hold the disengage knob (2) and move the lever in either direction. Release the knob and move the lever until the engine reaches the required revs.

## **Engine Stop Mechanism**

Diesel engines are stopped by preventing the fuel being injected into the cylinders. This is normally achieved by using a cable type control which is terminated with a control knob, usually marked 'STOP'. To stop the engine, pull and hold the control knob until the engine has stopped. Immediately the engine has stopped, push the control knob back to the 'RUN' position. Switch off the engine at the ignition.

**Note: If your engine fails to start, when the batteries are in good condition, check first that the engine 'STOP' control is in the 'RUN' position.**

## **ENGINE INSTRUMENTATION**

This varies, depending on the type of engine fitted, but most yachts are equipped with a rev counter, water temperature gauge, oil pressure warning light and charging warning light.

## **BASIC ENGINE CARE**

The following basic points, if adhered to, will ensure long engine life. The most critical period is the first 20 - 30 running hours.

1 Do not start an engine unless you are sure:

1.1 Engine oil level is satisfactory.

1.2 Gearbox oil level is satisfactory.

- 1.3 Coolant level is satisfactory (freshwater cooled engines only).
- 1.4 Throttle set correctly - out of gear.
- 1.5 Fuel stopcock is open.
- 1.6 Fuel is free from contamination.
- 1.7 Water inlet stopcock is turned on.
- 1.8 If the engine does not start after one or two attempts, do not continue to turn the engine over without turning the engine water inlet off. Seek an approved engine agents advice.
- 2 Immediately after starting, check:
  - 2.1 Oil pressure warning light extinguished.
  - 2.2 Charging light extinguished (or ammeter reading satisfactory).
  - 2.3 Water emission from exhaust.
- 3 Avoid high revs.
- 4 Allow engine revs to decrease to idle before changing gear.
- 5 Do not allow engine to run at a low idle for long periods.
- 6 During running, check any instrumentation, ie. water temperature gauge, oil pressure warning light, etc.
- 7 Prior to stopping engine, allow engine to idle for a few minutes with the morse lever in neutral.
- 8 After stopping engine, return 'STOP' control to the 'Run' position.

- 9 Ensure the first service is carried out by a manufacturer's recommended agent.
- 10 Ensure all subsequent servicings are carried out at the correct frequency.
- 11 Ensure only the correct lubricants are used.
- 12 Adhere to all manufacturer's recommendations.
- 13 Keep an engine log. (See Maintenance Log).

## **Maintenance**

Maintenance should be carried out in accordance with the manufacturers instructions. If you do not feel capable of undertaking any task, engage the services of a marine engineer.

## **Tools**

The following tools are required to carry out basic maintenance on Volvo 2000 series engines:

Combination Spanners - 8, 10, 13 & 17mm

Combination Spanner - 1/2" AF

8" Adjustable Spanner

Side Cutting Pliers

Flat Blade Screwdriver (7-10mm blade width)

Cross Point Screwdriver (Phillips type)

Stainless Steel Knife

Hexagon Headed Wrenches - 5 & 10mm (Allen Keys)

Oil Scavange Pump & Hose

For cylinder head tightening:

Torque Wrench capable of 70Nm (52 ft lbs)

17mm Socket to fit torque wrench

### **Maintenance Products**

A table of recommended products for use with the Volvo 2000 series engines is given in Table 1.

<i>PRODUCT</i>	<i>SIZE</i>	<i>VOLVO Pt. No.</i>
Coolant type 85	1 litre	1141523
	5 litre	1141524
Liquid gasket	25 gm	40879-1
SAE 20W/30 lubricating oil	1 litre	1141502-3
	5 litre	1141506-4
	25 litre	1141515-5
Inhibiting oil	1 litre	1141510-6
Grease	40 gm	828250-1
Propeller shaft grease	500 gm	1141509-8
Engine pain	400 ml	837176-7
	1 litre	837124-7
Universal oil	165 ml	281404-4
Rustproofing spray	400 ml	1161038-3

Table 1 - Recommended Products

## TURBOCHARGERS

Some Westerly yachts are fitted with the Volvo 2003T engine. The 'T' indicates that the engine is turbocharged.

Turbocharging is a form of supercharging which uses exhaust gases to drive a compressor to force more air into the cylinders. This means that more fuel can be injected into the cylinders, producing more power.

Fig. 4 indicates the difference in power output between the Volvo 2003 and 2003T.

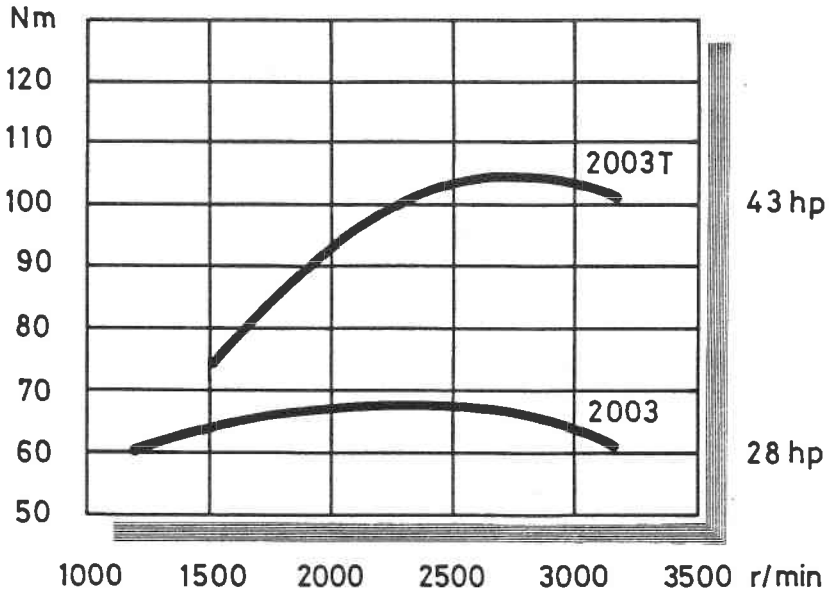

Fig. 4 - Power Difference 2003/2003T



## **Operating Instructions:**

No special operating instructions are required for the Volvo 2003T, but the following rules apply:

- 1 Do not run at idling speed for too long. The temperature in the combustion chamber becomes too low for effective combustion and the engine produces very unpleasant black exhaust fumes.
- 2 Do not attempt to charge batteries at idling speed as most generators/alternators only charge above 1500 revs.
- 3 If the engine has been run hard for a long period, let it idle for a few minutes before switching off. This is sometimes known as 'Turbo Run Down'. In all engines, it will avoid the risk of 'After Boil', a condition where the cooling system temperature continues to rise because of lack of circulation. Severe overheating causes bearing wear in the turbocharger.

## **Maintenance**

No special maintenance is required for the Volvo 2003T, but engine oil changes must be carried out at the correct frequency using the correct grade of oil. Correct lubrication is critical for turbocharged engines.

## **STERN GEAR**

Yachts are fitted with a 'P' bracket type stern bearing, (Fig. 5). The strut is bolted between hull stiffening webs. One securing bolt is electrically bonded to the sacrificial anode for cathodic protection. A water lubricated 'Cutlass' bearing (Fig. 6) at the end of the strut supports the outboard end of the stainless steel propeller shaft. The propeller shaft passes through a GRP stern tube, which is bonded to the hull. At the inboard end of the tube, is a water cooled rubber seal.

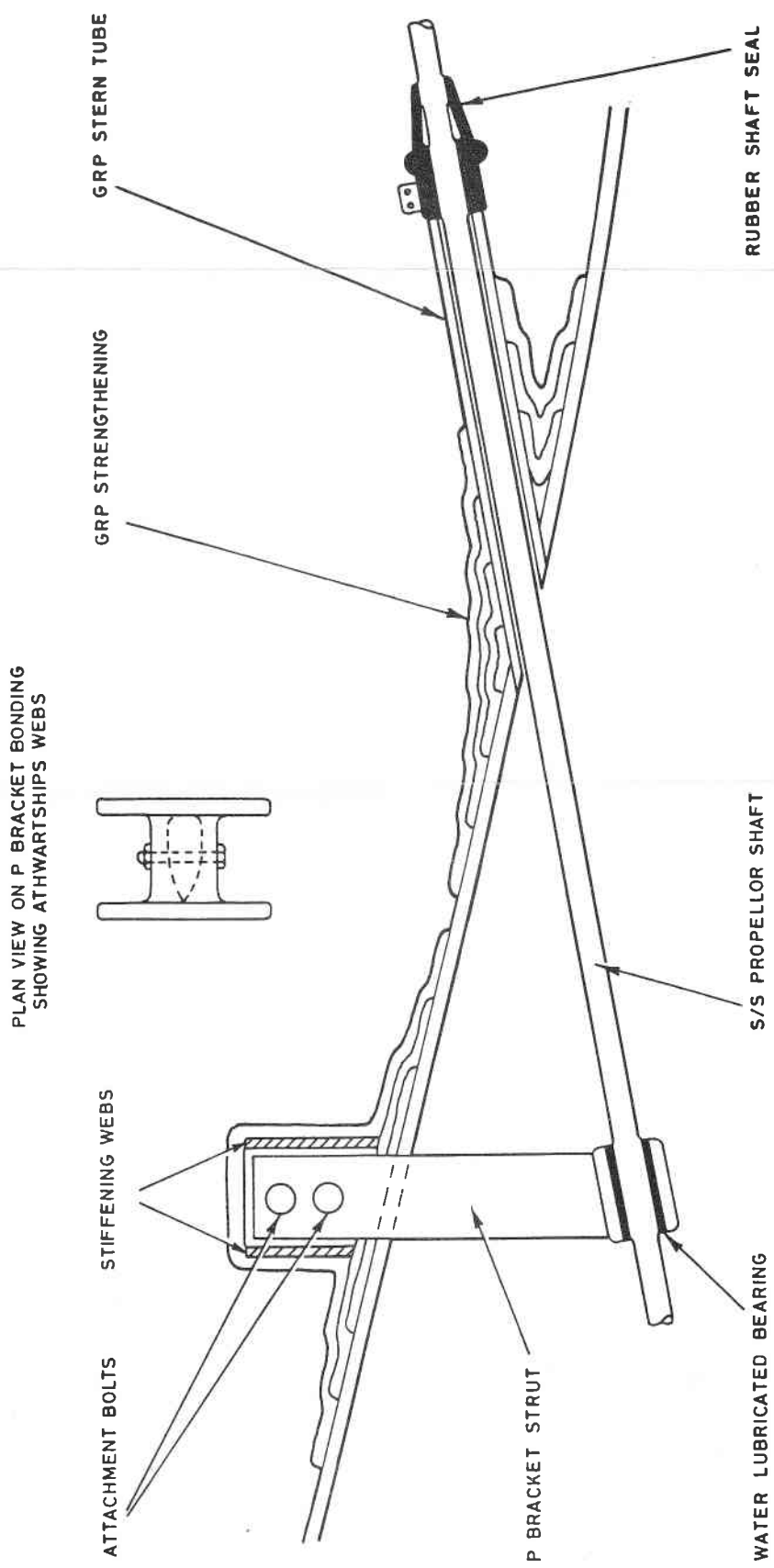

Fig. 5 - Stern Gear

## Cutlass Bearing

This type of water lubricated bearing is normally manufactured from neoprene or polyurethane and has a long life in clean water. High silt, sand and mud levels will cause accelerate wear.

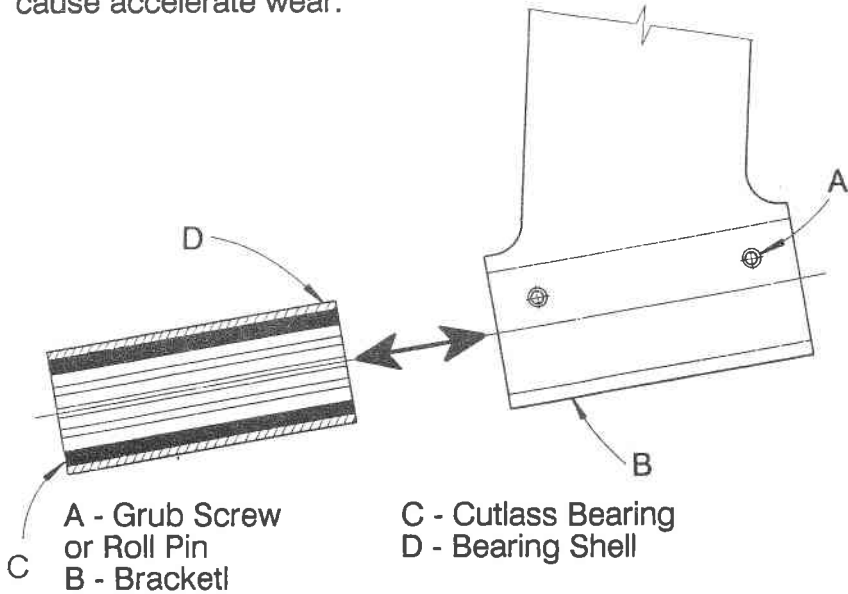

Fig. 6 - Cutlass Bearing

## Calcium Deposits

In certain areas where yachts remain unused for long periods, a hard calcium deposit may form on the propeller shaft. If this deposit forms between the joins in the cutlass bearing, when the shaft revolves for the first time, the hard calcium deposit can damage the bearing surface. This is normally associated with noise and vibration from the bearing area. If this happens, stop the engine immediately and investigate. The deposit can be removed with a sharp scraper. To gain access to the bearing area, uncouple the propeller shaft at the engine and slide it back until the affected area is exposed.

## Shaft Seal Venting

When the yacht is removed from the water, the water in the stern tube drains out. On relaunching, the air in the stern tube is forced up the seal area and causes an air lock. This prevents the water from reaching the seal and cooling it. This can cause serious damage to the seal if it is not 'vented' with the yacht in the water.

This only applies when the yacht has dried out for a long period, experience has shown that drying out between tides rarely causes damage.

### Venting Procedure

- 1 Compress the rubber seal at the lip and press towards the propeller shaft A, (Fig. 7). This will form a gap B between the shaft and the seal, allowing air to be vented.

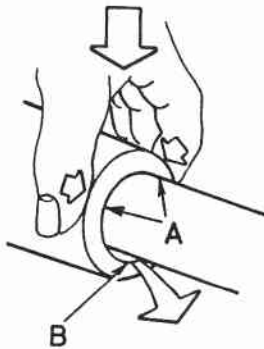

Fig. 7 - Venting

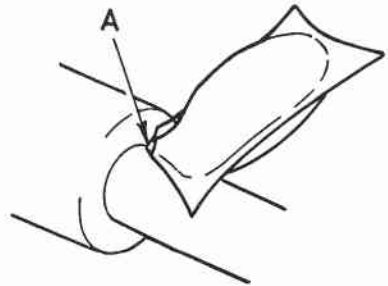

Fig. 8 - Lubrication

- 2 When water forces its way through the gap, release the seal. The seal is now vented, but must be lubricated.

### Lubrication

Press a small quantity (approx  $1 \text{ cm}^3$ ) of waterproof grease into the rubber seal A as shown in Fig. D8.

**Note: It is recommended that Volvo Grease Pt No 828250-1, or equivalent, is used.**

- 2 The seal should be lubricated after approximately 200 hours operation, or annually.

## **5. GAS SYSTEM**

GAS SYSTEM  
Maintenance  
Leaks

## GAS SYSTEM

The gas bottle(s) is stowed in a remote self draining locker. The regulator, connected either directly, or by a short flexible hose, to the bottle, reduces the gas pressure for the yacht's low pressure appliance(s). The supply to the cabin is by a copper pipe terminated near the appliance with a gas tap. The appliance (eg cooker), is connected to the gas tap by a short flexible hose, allowing it to move in its gimbal.

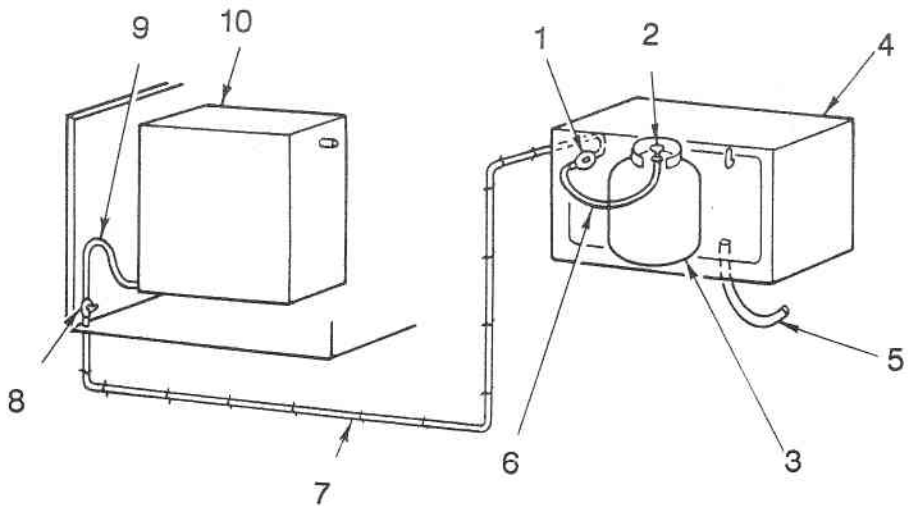

- 1 - Regulator
- 2 - On/Off Valve
- 3 - Gas Bottle
- 4 - Locker
- 5 - Drain

- 6 - Flexible Hose
- 7 - Copper Pipe
- 8 - Gas Tap
- 9 - Flexible Hose
- 10 - Cooker

Fig. 1 - Typical Gas System

## Maintenance

Maintained correctly, gas systems are safe and trouble free. At the start of each season and before any long voyage, the following checks are recommended:

- 1 All rigid pipes and fittings should be checked for corrosion.
- 2 All flexible pipes should be checked for perishing.

**Note: It is recommended that all flexible hoses are replaced annually.**

- 3 All gas taps and controls should be tested for operation.
- 4 Gas bottle lockers should be cleaned thoroughly and drains checked for blockages.
- 5 Regulators should be examined for corrosion or damage. If in doubt - do not attempt to repair a regulator - take it to your nearest gas stockist.

## Leaks

If you suspect that there is a leak in the system, check the pipework using a strong soapy solution, applied to the area in which you think the leak may be found. If a leak is detected and you are at all doubtful as to your ability to repair it, consult a qualified engineer.

**WARNING: DO NOT TEST FOR LEAKS WITH A NAKED FLAME.**



## **6. WATER/WASTE SYSTEM**

**EQUIPMENT CHART**

**WATER SYSTEMS**

**WASTE SYSTEMS**

**TOILETS**

**BRYDON MARINE TOILET**

Operating Instructions

Winterisation Procedure

Spare Parts

**BRYDON TOILET WITH HOLDING TANK**

Operating Instructions

## WESTERLY YACHT WATER/WASTE EQUIPMENT CHART

### CURRENT PRODUCTION YACHTS

YACHT	TANK CAPACITY (Galls)	PRESSURE SYSTEM + HOT WATER	GALLEY PUMP OR BACK-UP	HEADS		ADDITIONAL HEADS		
				WC	BASIN/SHOWER	WC	BASIN	SHOWER
KONSORT	30	NO	FOOT PUMP	BRYDON	HAND PUMP			
KONSORT DUO	100	YES	FOOT PUMP BACK-UP	BRYDON	COMBINED TAP/ SHOWER HEAD			
TEMPEST	30	NO	HAND PUMP	BRYDON	HAND PUMP			
FULMAR	30	NO	FOOT PUMP	BRYDON	FOOT PUMP			
STORM	40	NO	FOOT PUMP	BRYDON	FOOT PUMP			
STORM CRUISING	40	YES	FOOT PUMP BACK-UP	BRYDON	COMBINED TAP/ SHOWER HEAD			
RIVIERA	40	YES	FOOT PUMP BACK-UP	BRYDON	COMBINED TAP/ SHOWER HEAD			
SEAHAWK	60	YES	FOOT PUMP BACK-UP	BRYDON	COMBINED TAP/ SHOWER HEAD			H & C
FALCON	65	YES	FOOT PUMP BACK-UP	BRYDON	COMBINED TAP/ SHOWER HEAD	BRYDON		H & C
CORSAIR	70	YES	FOOT PUMP BACK-UP	BRYDON	COMBINED TAP/ SHOWER HEAD	BRYDON		H & C
OCEANLORD	110	YES	FOOT PUMP BACK-UP	BRYDON	COMBINED TAP/ SHOWER HEAD	BRYDON		COMBINED TAP/ SHOWER HEAD

**Note: The Oceanlord is fitted with pumped shower drains.**

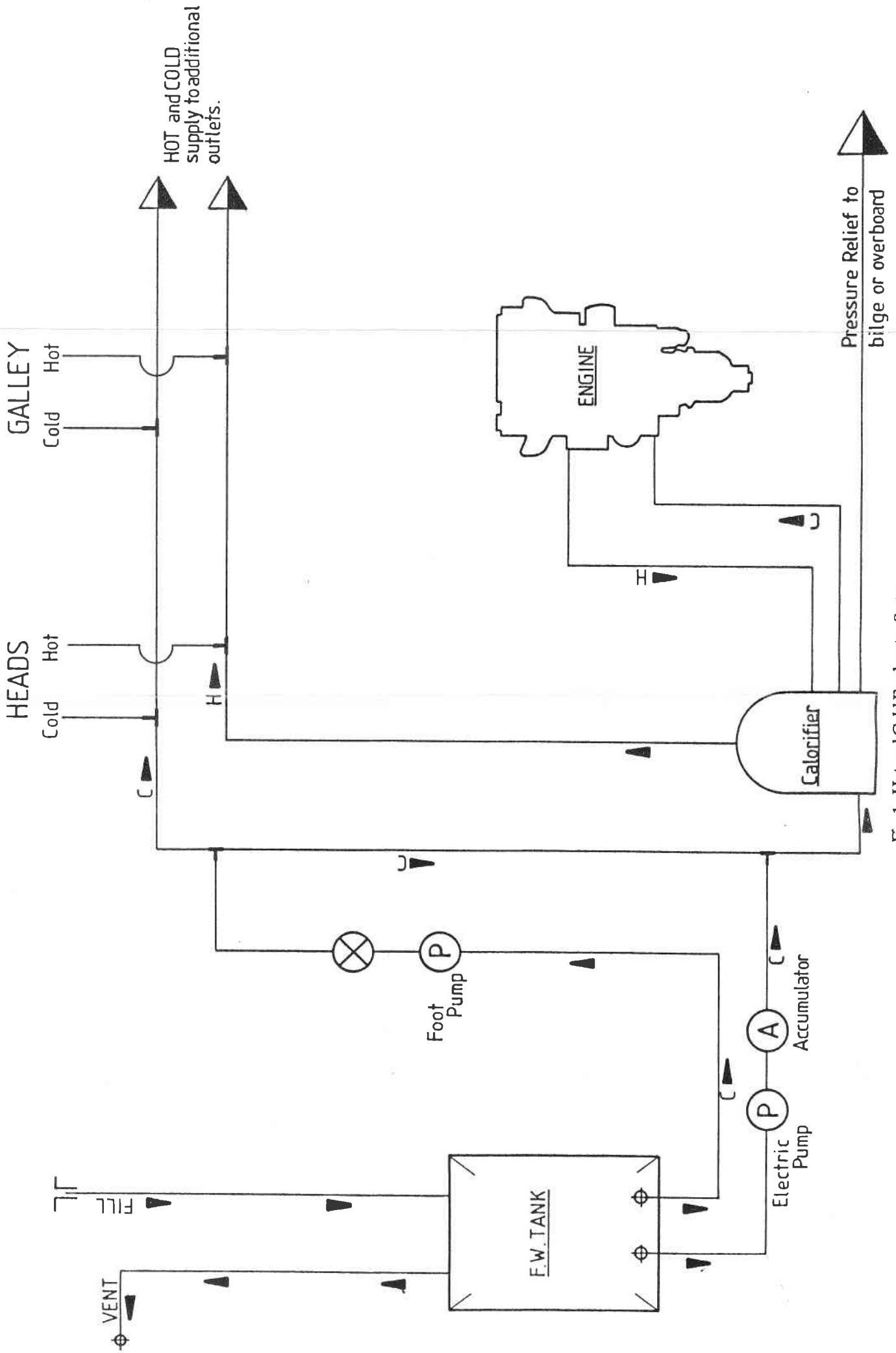

Fig. 1 - Hot and Cold Freshwater System

### **Notes:**

- 1 The valve lever should be left in the 'DRY BOWL' position when the toilet is not in use.**
- 2 Always close the inlet and outlet seacocks when the yacht is to be left unattended.**

### **Winterisation Procedure**

- 1 Remove drain plug in base of toilet.**
- 2 Ensure valve lever is in 'DRY BOWL' position.**
- 3 Operate pump.**

### **Notes:**

- 1 In salt water areas, flushing with fresh water is recommended.**
- 2 Do not use antifreeze, acids, harsh alkalis, Javex or household bleach.**
- 3 After a long period of non-use, it is recommended that the inner surface of the pump cylinder is lightly coated with vaseline.**

### **Spare Parts**

Toilets are supplied with an illustrated parts list with UK and US contact addresses. Any Brydon, Par or Jabsco distributor should stock spare parts.

### **BRYDON TOILET WITH HOLDING TANK**

If required yachts are fitted with a holding tank system as illustrated in Fig. 2.

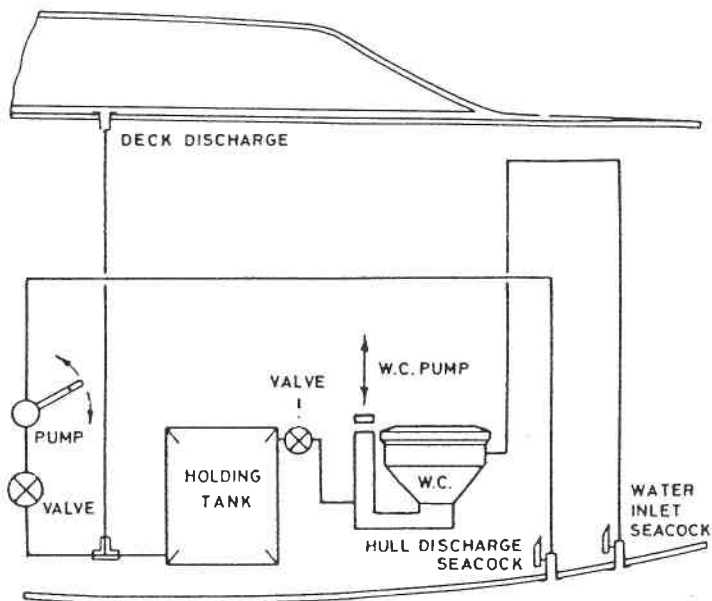

Fig. 2 - Brydon Toilet with Holding Tank

### Operating Instructions:

- 1 Open inlet and outlet seacocks.
- 2 Discharge toilet into holding tank.

### Deck Discharge Only

- 3 Connect discharge equipment to deck outlet.
- 4 Operate discharge equipment.
- 5 Remove discharge equipment.
- 6 Secure deck discharge outlet.

### **Hull Discharge Only**

- 3 Pump out waste.
- 4 Close hull inlet seacock.
- 5 Close inlet seacock.

## 7. ELECTRICAL SYSTEMS

BASIC ELECTRICAL SYSTEM

BATTERIES

BATTERY ISOLATION SWITCHES

SWITCH PANELS

POWERCENTRE

Switches

DC Circuit Breakers

Battery Condition

Use of the System

Engine Battery

Battery Charging

Single Battery Operation

Mains Powered Battery Charging

IYS SWITCH PANEL

# BASIC ELECTRICAL SYSTEM

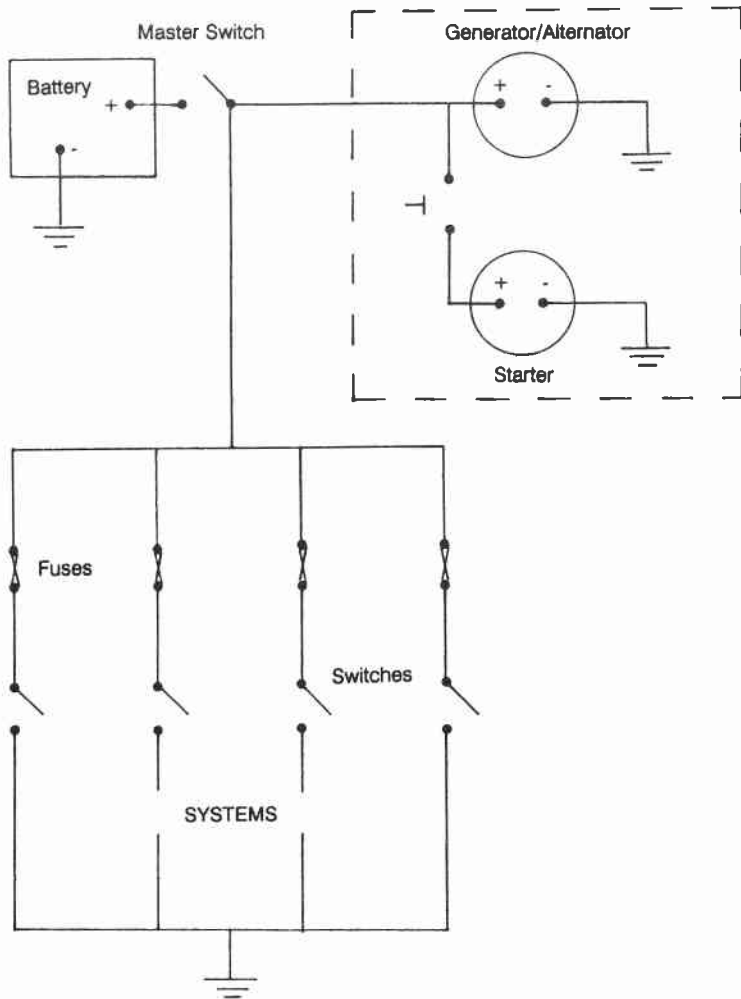

Fig. 1 - Basic Electrical System



## BATTERIES

Yachts use a 12 volt electrical system comprising either one or two batteries. It is recommended that the 'sealed for life' type of battery being fumeless and requiring limited maintenance, is used.

If two batteries are fitted, they are usually connected to either a dual isolation switch or two individual isolation switches.

## BATTERY ISOLATION SWITCHES

Fig. 2 illustrates the Hella type circuit.

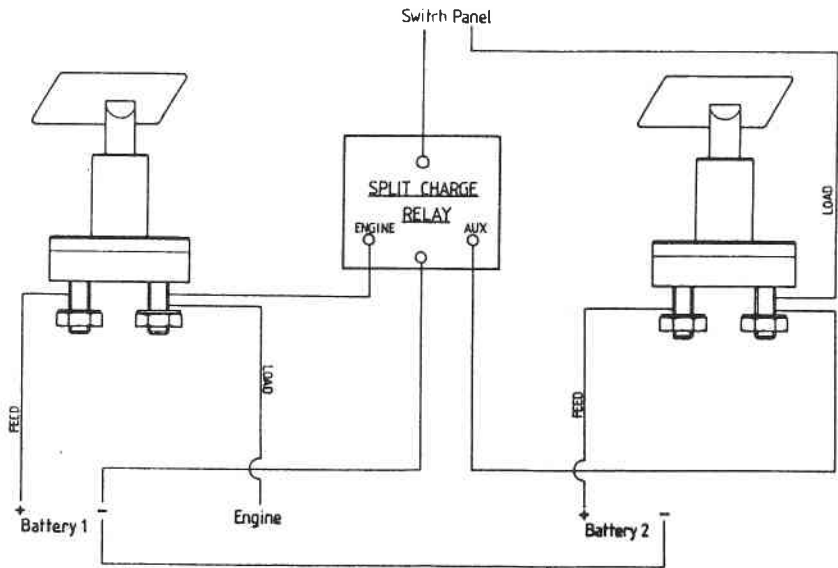

Fig. 2 - Hella Type Battery Isolation Circuit

Selected yachts were fitted with the Vetus Battery Isolation Switch (Fig. 3).

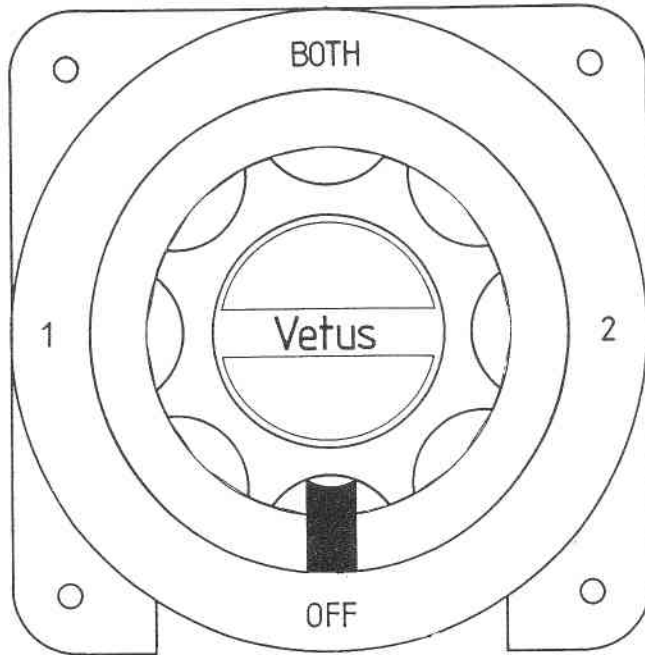

Fig. 3 - Vetus Isolation Switch

This type of isolation switch allows both batteries to be connected in parallel for engine starting. If your yacht is fitted with this type of switch and has two batteries fitted, the following points should be noted:

- 1 Always switch off batteries when not required and not on charge.
- 2 Use one battery for the engine and one for auxiliary use. When the auxiliary battery goes flat, do not switch to the engine battery. Start the engine, using the engine battery, and fully charge the system.

- 3 Try to keep the auxiliary battery fully charged, this will enable it to be used to start the engine if the engine battery is flat.

## SWITCH PANELS

Two types of switch panel are currently fitted, the 'Powercentre' and the 'IYS'.

### POWERCENTRE

This comprises circuit switches with illuminated displays, circuit breakers and a battery status display.

#### Switches

These control the output of the battery circuit to the various systems. The switch legend, to the right of the switch, lights when the circuit is switched on.

#### DC Circuit Breakers

These are controlled by a touch activated membrane at the bottom of the panel (Fig. 4).

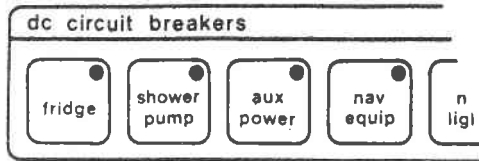
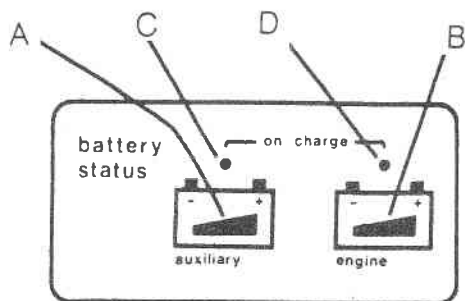

Fig. 4 - DC Circuit Breakers

If a circuit is tripped, a visual indication is given on the relevant circuit breaker touch panel. To reset the circuit breaker, press the touch panel for the relevant circuit and the light will extinguish when the circuit is reset.

## Battery Condition

This is indicated on an illuminated battery status panel (Fig. 5).



- A - Auxiliary Battery Indicator
- B - Engine Battery Indicator
- C - Auxiliary Battery Charge Light
- D - Engine Battery Charge Light

Fig 5. - Battery Status Panel

### Use of the system

Switch on the auxiliary battery isolation switch, then providing all circuit switches are off and no load is applied to the battery, the auxiliary indicator (A) will show:

Green (System OK - charge above 50%). Red (System low - charge below 50% - requires charging).

With a load applied to the battery, the auxiliary indicator will show:

Green (System OK - charge above 50%). Yellow (Charge between 25% and 50% - recharge battery). Red (Charge below 25% - recharge battery urgently). Red (Flashing) - (Charge below 10% - battery level critical - recharge now).

**Note: If load is removed when indicator is yellow, it will revert to green. Red and red (flashing) will remain on until battery is recharged.**

## **Engine Battery**

Switch on the engine battery isolation switch, engine indicator (B) will show:

If 'Off Load':

Green (System OK - charge above 60%). Yellow (caution - Charge between 50% and 60% - recharge battery). Red (danger - Charge below 50% - recharge battery urgently).

**Note: When starting the engine, the display will change to red.**

## **Battery Charging**

When the engine is running, the generator/alternator will charge the system as follows:

- 1 Engine on charge indicator (D) will light.
- 2 Auxiliary on charge indicator (C) will light when the split charge relay engages.
- 3 Auxiliary and engine indicators (A & B) will light. This indicates they have reached minimum recharge level. Run engine for 2 hours to obtain satisfactory charge level.

**Note: When the engine is switched off, the yellow charging indicators (C & D) will remain on for approximately 2 minutes and the split charge relay will disengage.**

### **Single Battery Operation**

- 1 Battery level indicated on engine display (B).
- 2 On charge light (D) will indicate battery is on charge.
- 3 Engine display is green when the minimum charge level is reached.
- 4 The auxiliary display (A) is red when lights etc. are used without the engine running.

### **Mains Powered Battery Charging**

A mains powered battery charger is available for use with the Powercentre. Further information is available from:  
Kdd Powercentre Limited, Tregonigie Ind Est, FALMOUTH,  
Cornwall. TR11 4SN.

# IYS SWITCH PANEL

- |    |            |
|----|------------|
| 1  | Aft Cabin  |
| 2  | Saloon     |
| 3  | Fwd Cabin  |
| 4  | Deck       |
| 5  | Compass    |
| 6  | Shower     |
| 7  | Water      |
| 8  | Navigation |
| 9  | 9 nsts     |
| 10 | Aux 4      |
| 11 | Aux 3      |
| 12 | Aux 2      |
| 13 | Anchor     |
| 14 | Strig      |
| 15 | Nav 2      |
| 16 | Nav1       |
| 17 | Negative   |
| 18 | Aux 1      |
| 19 | Positive   |

## 8. MAINTENANCE

### HULL

- Keel Bolts
- Detection
- Repair a Leaking Keel Bolt
- Skin Fittings & Seacocks
- Sacrificial Anodes
- Antifouling

### SAILS & RIGGING

- Sails
- Ropes

### STEERING SYSTEMS

- Rudders
- Wheel Steering Systems
- Hydraulic Steering Fault Finding

### ENGINE SYSTEMS

- Fault Finding
- Maintenance
- Stern Gear

### GAS SYSTEM

- Maintenance
- Leaks

### WATER/WASTE SYSTEMS

- Brydon Toilet
- Lavac Toilet
- SL 400 Toilet

### WINTERISATION/DEWINTERISATION

### CLEANING



## **HULL**

### **Keel Bolts**

Despite being fully sealed and bonded at the time of manufacture, the hull/keel joint is a primary target for leaks. Running aground or standing on bilge keels will increase the risk.

**CAUTION:** The following information is provided to assist suitable experienced marine engineers and assumes that suitable equipment and conditions are available to carry out the repair procedures.

**Westerly Yachts Limited cannot be held responsible for any damage incurred using the procedures.**

### **Detection**

A leaking keel bolt, will nearly always produce rust staining. This is a result of staining from the keel surface and not from the fittings which are stainless steel. Leaking bolts normally leak all the time, not just when sailing. If leaking occurs only when sailing, it is normally associated with a major structural fault which should be closely inspected. If a leak is suspected but there is no sign of staining, the following procedure should be adopted:

- 1 Dry the suspected area thoroughly.
- 2 Place a ring of 'plasticine', or similar, around the suspected bolt(s).
- 3 Check the area for signs of water within the ring. If water becomes trapped in the area, it is likely there is a leak.

### **Repairing a Leaking Keel Bolt**

Leaking keel bolts must be tackled one at a time. Required tools and materials are as follows:

- 1 A suitably sized socket or spanner:

1978 to date - Metric

1975 to 1978 - Whitworth or Metric

Pre 1975 - Whitworth

- 2 A scraper.
- 3 Rag or other drying medium.
- 4 Caulking cotton.
- 5 Thiosulphide sealant (Keelbond or Thiofix etc.).

The following procedure is carried out from inside the hull.

- 1 Having identified the relevant bolt, remove the protective gelcoat.
- 2 Undo the locknut, using the correct sized socket or spanner (Fig. 1).
- 3 Remove the nut and small washer.
- 4 Remove the plate washer and clean ready for reassembly. Seepage will occur if the yacht is in the water.
- 5 Thoroughly dry the area using a suitable material.
- 6 Make up a ringlet of caulking cotton as shown in Fig. 2.

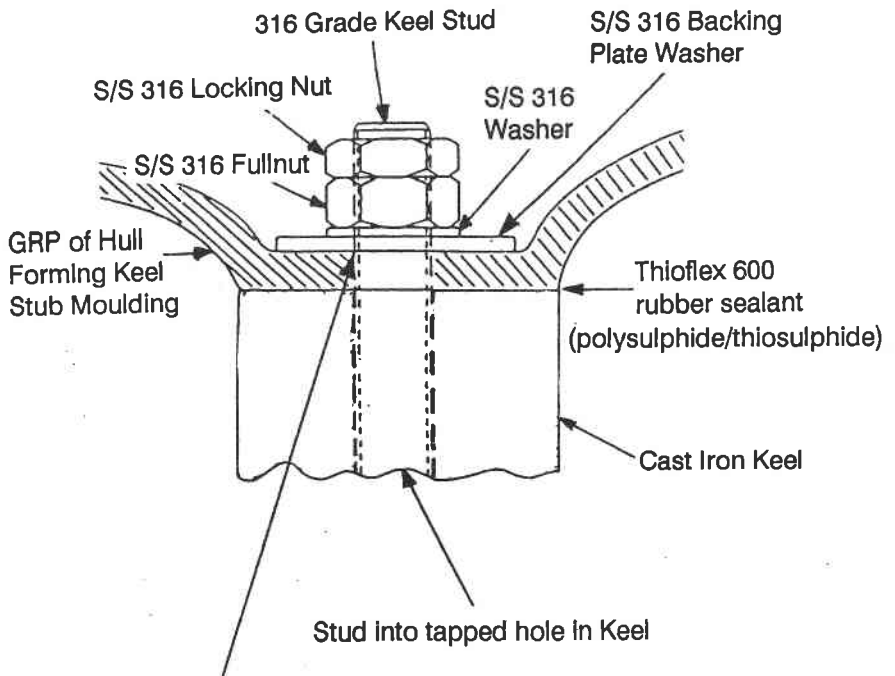

When attending to Keel bolt leaks  
caulking cotton ringlet to be  
positioned here prior to replacement  
of plate washer.

Fig. 1 - Typical Keel Bolt Installation

Start by forming a 4 or 5 strand loop around a finger or other suitably sized object, approximately 1/4" (6mm) larger than the bolt. Wind the cotton around the loop.

Continue winding the cotton in a spiral fashion until the internal diameter is slightly less than the bolt. This will ensure a snug fit. The section through the ringlet should be approximately 1/4" to 5/16" (6 - 8mm) diameter.



Fig. 2 - Ringlet

- 7 Fit the ringlet of caulking cotton to the bolt.
- 8 Apply sealant to the underside of the plate washer and put in on the bolt.

- 9 Fit the plain washer and nut. Tighten the nut. Westerly Yachts Ltd do not use a torque setting for tightening keel bolts, but as a guide, 24mm bolts should be tightened to 150ft lbs, 20mm bolts to 85ft lbs and 15mm bolts to 55ft lbs.
- 10 Fit and tighten the locknut to 30% of the torque figure required for the full nut.
- 11 When the sealant has cured, coat the whole assembly with gelcoat. Resin or paint will suffice if gelcoat is not available. This will both seal and lock the threads.
- 12 Regularly inspect the repaired area for signs of leaks until satisfied that the repair is totally watertight.

## **Skin Fittings & Seacocks**

### **Gate Valves**

Check regularly:

- 1 Free operation of valve.
- 2 Security and condition of hose and hose clip.

If valve is jammed or fails to operate correctly, it should be replaced.

### **Sleeve Valve**

Check regularly:

- 1 Free operation of valve.
- 2 Seal between body and core.
- 3 Security and condition of hose and hose clip.

If valve is stiff:

- 1 Remove core from body.
- 2 Clean, regrease and replace.

If valve is leaking:

Check security of bolts, tighten as necessary.

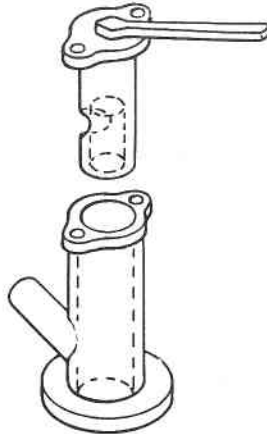

Fig 3 - Sleeve Valve.

Ball Valve

Check regularly:

- 1 Free operation of valve.
- 2 Security and condition of hose and hose clip.

## Skin Fitting Gate Valve with Strainer

This type is fitted to some early yachts (Pre 1982).

Check regularly:

- 1 Free operation of valve.
- 2 Cleanliness of strainer.
- 3 Security and condition of hose and hose clip.
- 4 Cathodic bonding if applicable.

If valve is jammed or fails to operate correctly, it should be replaced.

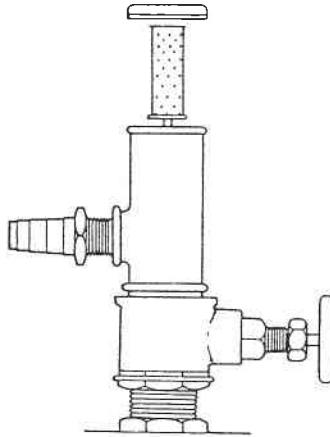

Fig 4 - Gate Valve.

## **Sacrificial Anodes**

These must be checked annually. If the yacht is not lifted and winterised the anode can be checked by hand from a dinghy. If this is not possible, allowing the yacht to 'dry out' on soft mud will enable it to be checked between tides. See Hull section for further information.

## **Antifouling**

This should be checked annually. If the yacht is not lifted, allow the yacht to 'dry out' on soft mud between tides to provide an opportunity for inspection.

## **SAILS AND RIGGING**

Rigging checks and adjustments are detailed in the Sails and Rigging section.

### **Sails**

Sails should be checked regularly during the season for the following:

- 1 Chaffing (Mainly at spreaders and on foot of large sails).
- 2 Tears at batten pockets and all attachment points, Tack, Clew, Head, Hails and Reefing Cringles.
- 3 Other damage.

### **Ropes**

All ropes should be checked regularly during the season for the following:

- 1 Damage to whipping or heat shrink sleeves.



- 2 Signs of wear or damage where constantly cleated, clamped, passed round sheave blocks or through fairleads.
- 3 Splices are serviceable. This is particularly important where nylon ropes are spliced to steel wire ropes, such as halyards.

## **STEERING SYSTEMS**

### **Rudders**

Rudders become less efficient as bush wear increases. Bushes should therefore be checked at the end of each season and repaired as necessary. See Steering Systems section for typical bush arrangement.

### **Wheel Steering Systems**

**Edson.** Maintenance should only be carried out if in possession of the relevant repair information sheet available from Westerly Yachts Limited or an Edson agent.

Lubrication of the cables and quadrant should be carried out annually. On extended voyages, it is recommended that lubrication is carried out weekly.

**Whitlock.** See Pre 1988 Section for information on Cobra, Mamba and Titan systems.

### **Hydraulic Steering Fault Finding**

**Note:** Sometimes when returning the wheel from hard-over, a slight resistance may be felt and a clcking noise heard. Do not mistake this for a fault.

**FAULT 1** - Steering stiff (even when craft is not moving).

**PROBABLE CAUSE** - Mechanical binding at rudder, bushes/bearings binding.

**ACTION** - Disconnect ram from tiller arm and check. If still stiff, check for restriction in hose, repair as necessary. If no hose restriction, check viscosity of fluid. Drain and refill as necessary.

**FAULT 2** - Rudder drifts when underway.

**PROBABLE CAUSE** - Dirt in system.

**ACTION** - Drain, flush and refill, then recheck.

**FAULT 3** - Leaking seals.

**ACTION** - Replace seals or unit.

## ENGINE SYSTEMS

### Fault Finding

#### Engine Problems - Starting

##### *Trouble Starting*

##### *Cause*

Starter fails to turn, or turns too slowly.

- 1 Battery not connected, or insufficient charge.
- 2 Terminals corroded or loose.
- 3 Starter switch damaged.
- 4 Solenoid switch faulty.
- 5 Starter motor clutch slips.
- 6 Starter motor brushes shorting to earth.
- 7 Broken terminal to carbon brushes.

1 - 2 will occur suddenly.

3 - 7 will produce symptoms of progressive deterioration.

Starter motor turns, but does not engage in engine.

Pinion or ring gear dirty or damaged.

## Engine Problems - Starting

<i>Trouble Starting</i>	<i>Cause</i>
Starter continues to run after ignition switch returned to 1.	<ol style="list-style-type: none"><li>1 Ignition switch defective.</li><li>2 Starter solenoid jammed.</li></ol>
Pinion fails to disengage after engine has started and running.	<ol style="list-style-type: none"><li>1 Shut down immediately. Starter motor defective.</li></ol>
Engine does not start though starter operates normally	<ol style="list-style-type: none"><li>1 Heater plugs faulty.</li><li>2 Fuel stoppage. Check tank, fuel delivery, for empty or blockage.</li><li>3 Engine compression low.</li><li>4 Valve clearances too small.</li><li>5 Valve springs broken.</li><li>6 Piston rings damaged.</li><li>7 Cylinder head gasket defective.</li></ol>

## Engine Problems - Running

<i>Trouble Running</i>	<i>Cause</i>
Speed and power decreased.	<ol style="list-style-type: none"><li>1 Fuel running low.</li><li>2 Delivery lines leaking.</li><li>3 Air entering injector pump.</li><li>4 Needle valve in injector jammed.</li><li>5 Incorrect valve clearance.</li><li>6 Blocked air filter.</li><li>7 Blocked fuel filter.</li><li>8 Silencer blockage increasing back pressure.</li></ol>

## Engine Problems - Running

### *Trouble Running*

### *Cause*

Engine knocks (unusual engine noise).

- 1 Injector needle sticking or leading causing low fuel metering into precombustion chamber.
- 2 Fuel lines partially blocked or leaking.
- 3 Fuel injection out of synchronisation with crankshaft timing.
- 4 Damaged crankshaft. Shut down engine immediately.

Engine emits blue exhaust gas.

- 1 Oil level too high (over filled).
- 2 Oil bath air cleaner oil level too high.
- 3 Valve guides worn.
- 4 Piston rings damaged or stuck.

Engine emits white exhaust gas.

- 1 Water in coolant entering combustion chamber - faulty cylinder head gasket.
- 2 Injector maladjusted - fuel delivery incorrect causing unburnt fuel emission.
- 3 Fuel injection out of synchronisation with crankshaft timing.

Coolant temperature too high.

- 1 Lack of coolant.
- 2 Coolant system contains sludge.
- 3 Vee belt slack or broken to water pump.
- 4 Defective water pump mechanism.
- 5 Defective thermostat unit.
- 6 Cylinder head gasket leaking.

## Engine Problems - Running

### *Trouble Running*

### *Cause*

Vapour emission from engine unit. Shut down engine immediately.

- 1 Coolant water entering engine lubrication system.
- 2 Oil level too high.
- 3 Piston rings seized, broken or jammed.
- 4 Crank gear damaged - bearings seized due to lack of oil or insufficient oil filtering.

Oil pressure too low. If sudden, shut down engine immediately.

- 1 Low oil level in sump.
- 2 SAE grade too low.
- 3 Pressure relief valve faulty.
- 4 Defective oil pump.
- 5 Bearings worn to excessive clearances.
- 6 Defective oil pressure gauge.

Engine stops or sudden power loss.

- 1 Leak in fuel line/injector.
- 2 Vent line in fuel tank blocked.
- 3 Blockage in fuel system.
- 4 Piston seized, or crank gear damaged. Shut down engine immediately.

## Maintenance

Maintenance should be carried out in accordance with the manufacturer's instruction. See Engine Systems Section for details on Volvo engines and also basic engine care.

## **Stern Gear**

Calcium Deposits - see Engine Systems Section.

Shaft Seal Venting - see Engine Systems Section.

Shaft Seal Lubrication - see Engine Systems Section.

## **GAS SYSTEM**

Maintenance - see Gas Systems Section.

Leaks - see Gas Systems Section.

## **WATER/WASTE SYSTEMS**

### **Brydon Toilet**

Winterisation - see Water/Waste System Section.

Spare Parts - see Water/Waste System Section.

### **Lavac Toilet**

Maintenance - see Water/Waste System Old Models Section.

Winterisation - see Water/Waste System Old Models Section.

### **SL 400 Toilet**

Spare Parts - see Water/Waste System - Old Models Section.

## **WINTERISATION/DEWINTERISATION**

Westerly Yachts recommends that all vessels are taken out of the water every year. All plastics absorb moisture when immersed in water. If you wish to keep your vessel in top condition, it should be allowed to dry out.

## LAYING UP CHECKLIST

1 If hauled out and propped up, check:

Security of props and shores

Wedges between shores and topsides

Stakes to stop lower ends moving

Secure fore and aft (top and bottom)

Prop under forefoot

Is it safe against likely wind directions and vandals?

2 Check insurance covers layed up period.

3 Ensure adequate ventilation while leaving boat.

4 Consider heating. Ideally greenhouse heater bars on lateral wood struts taking them well clear of joinery etc., if the boat is afloat and likely to move. Central heating by thermostat or time control or both.

5 Remove cushions for cleaning and storage.

6 Prop open all locker doors and hatches to air.

7 Take home everything likely to rust - pans, old galley gear.

8 Winterise engine as advised.

9 Blow through all water pipes to avoid a frozen pipe splitting later. Clean tanks.

10 Remove batteries for cleaning, periodical charging and storage.



- 11 Plan engine and stern gear maintenance - such as renewed stern gland packing, replace exhaust silencer if necessary.
- 12 Take sails ashore for cleaning and valetting. Note particular areas you wish sailmaker to check.
- 13 Plan sail modifications, recutting or replacement (remember winter discounts).
- 14 Dry store sails ashore when work completed.
- 15 If possible cover the deck, coach roof and deck joinery to reduce cleaning effort on fitting out. Make sure cover is supported clear of woodwork.
- 16 Undress mast rig - old halyards as gantlines.
- 17 Wash all running rigging, check and replace as required.
- 18 Check over standing rigging. Replace rigging screws, shackles, terminals, if there are signs of wear.
- 19 Check mast fittings - tracks, sheaves, blocks, spreader sockets, etc.
- 20 Wash oilies as manufacturer recommends, send away for repair as required.
- 21 Remove old or loose antifouling and recoat, rub down and recoat varnish for winter protection.

### **PROCEDURE FOR WINTERISING ENGINES**

The following procedures should be carried out on all yachts prior to winter storage:

- 1 After engine has been run up with coolant water mixed with anti-freeze, this should be drained completely.

- 2 Where engines are freshwater cooled, anti-freeze should be added to closed circuit system to manufacturer's recommendation.
- 3 Disconnect exhaust tubing from engine; using plastic tape, tape over exhaust outlet on engine. Pinch up jubilee clip onto exhaust tube so that it can be found easily when commissioning.
- 4 Remove air cleaner, tape up air inlet on engine and inlet and outlet ports on air cleaner itself, store air cleaner in galley locker.
- 5 Remove impeller(s) from coolant water circulating pump and secure to pump for easy location when commissioning.
- 6 Leave lubrication oil (Volvo 114/1506-4 CD/SAI API service which has rust preventing properties good for four months - not Adfilm type inhibiting oils) in engine, this is good for use until first service after commissioning.
- 7 Completely fill fuel tank.

### **Electrics and General**

- 1 Disconnect ship's batteries and pull battery cables well clear of terminals.
- 2 Spray exposed electrics and wiring terminations with WD40, and pay particular attention to battery master switch.
- 3 Ensure batteries are moved from items of equipment such as echo-sounders, radios, logs, etc.
- 4 Completely dry out toilet installation after testing.
- 5 Ensure domestic fresh water system is drained as far as possible.

## **Procedure for Dewinterising**

Cooling System (Sea Water) - Close drain taps, open sea water inlet valve.

(Fresh Water) - Fill cooling system with coolant.

Lubricating System - Drain inhibiting oil, replenish sump with lubricating oil.

Fuel System - Bleed fuel lines as necessary.

Exhaust System - Remove tape blanks and reconnect exhaust hose.

Electrical - Recharge batteries, then connect terminals.

Air Filters - Remove tape blanks and reconnect air filters.

## **CLEANING**

Instructions for the removal of stains from Cushion Fabrics  
Cushion covers contain inherent properties which promote the release of stains, but this is only effective if the stain is acted upon immediately.

**Note: Do not dry clean, do not machine wash.**

For the best results remove the stain as soon as possible and work from the outer edge to the centre of the stained area.

### **Removal of Stains**

- 1 Fresh stain - remove excess moisture with kitchen roll or alike by blotting. Do not rub the stained area as this spreads the stain.
- 2 Dried stain - break up stain and remove the loose particles by lightly brushing and/or vacuuming.

- 3 After removing excess moisture or dried material, moisten the stained area with upholstery cleaning agent.

**CAUTION: Use only the amount of cleaning agent required to do the job. Excess can spread stain and result in absorption by the cushion.**

If the stain persists, apply a common household spot remover. Apply spot remover to a clean cloth or sponge. Do not apply spot remover directly to the fabric. Test the solvent on an inconspicuous area before using on the stain itself.

Most stains can be removed with a mild solution of detergent. Sponge up excess detergent to minimize resoiling. Blot with a clean damp sponge and repeat until all excess detergent is removed.

### **Stains removable with household shampoo or detergent**

Alcoholic drinks, blackberries, crayon, egg, jam, sauces, fruit juice, milk, mud, ice cream, chocolate, strawberries, tea, wine, mascara, food dye, charcoal, coffee, soup, toothpaste, hand lotion, coca cola, mustard, ink and urine.

### **Stains removable with spot remover**

Butter, candle wax, gravy, lipstick, furniture polish, shoe polish, lard, chewing gum, hair tonic, crayon, salad dressing, engine oil and margarine.

**WARNING: Loose cushion covers if removed should never be hand or machine washed.**

### **Cleaning Vinyl Uholstery**

- 1 Remove all dust from area.
- 2 Wash area with soap and water. This will remove coffee and food stains etc.

## **Grease and oil stains**

These will need an oil solvent such as White Spirit or paraffin. Apply with a cloth. Be sure not to rub for long periods of time, as this may remove the material print.

**WARNING: Do not use any materials such as petrol, cellulose thinners, or any materials containing acetone solvent. These materials will remove the pattern and leave a light patch which cannot be repaired.**

## **Finishing**

Wash with soap and water, then finish with a good upholstery polish.

Do not clean vinyls with cleaners or solvents containing silicone.

## **Cleaning Drayon Velvets**

For long life care should be taken to remove dust and grit, gently brushing with a medium bristle brush, followed by the use of a hand vacuum cleaner.

Stains should be removed immediately with a slightly damp cloth.

Clean regularly with a dry foam upholstery shampoo (follow manufacturer's instructions). Do not soak or rub the pile heavily. Never use a detergent. Use warm water, never hot. Do not dry clean or machine wash.

## 9. SPECIFICATIONS

Konsort 29  
Konsort Duo  
Tempest 31  
Fulmar 32  
Storm 33  
Storm 33 Cruising  
Riviera 35  
Seahawk 35  
Falcon 35  
Corsair II 36 – Sloop  
Sealord 39 – Sloop  
Oceanlord 41 – Sloop

## KONSORT 29

### SPECIFICATION

Length Overall (excluding rudder)	28'10"	8.8m
Length Waterline	25'6"	7.77m
Beam	10'9"	3.29m
Draft	5'4"	1.62m
Fin Keel	3'3"	0.99m
Twin Keels		
Displacement	9211lbs	4178kg
Ballast	3200lbs	1451kg
Fin Keel	3200lbs	1451kg
Twin Keels		
Mast Height	35'9"	10.89m
<i>SAIL AREAS</i>	<i>sq ft</i>	<i>sq m</i>
Mainsail	180.0	16.72
No 1 Genoa	333.0	30.94
No 2 Genoa	257.0	23.88
No 1 Jib	168.0	15.61
No 2 Jib	120.0	11.15
No 3 Jib	68.0	6.32
Spinnaker	753.0	69.96

## KONSORT DUO

### SPECIFICATION

Length Overall (excluding rudder)	28'10"	8.8m
Length Waterline	25'8"	7.81m
Beam	10'9"	3.29m
Draft Twin Keels	3'4"	1.00m
Displacement	10100lbs	4581kg
Ballast Twin Keels	3200lbs	1451kg
Mast Height	35'9"	10.89m
<b>SAIL AREAS</b>	<i>sq ft</i>	<i>sq m</i>
Mainsail	176.0	16.4
No 1 Genoa	339.0	31.54
No 2 Genoa	248.0	23.09
No 1 Jib	167.0	15.52
No 2 Jib	122.0	11.36
No 3 Jib	67.0	6.25
Spinnaker	740.0	68.77



## TEMPEST 31

### SPECIFICATION

Length Overall	30'4"	9.25m
Length Waterline	24'6"	7.5m
Beam	10'10"	3.32m
Draft		
Fin Keel	4'11"	1.53m
Twin Keels	3'9"	1.15m
Displacement	9020lbs	4100kg
Ballast		
Fin Keel	2684lbs	1220kg
Twin Keels	2860lbs	1300kg
Mast Height	41'9"	12.73m
<i>SAIL AREAS</i>	<i>sq ft</i>	<i>sq m</i>
Mainsail	190	17.6
No 1 Genoa	333	30.95
No 2 Genoa	267	24.8
No 1 Jib	212	19.69
No 2 Jib	165	15.3
Storm Jib	70	6.48
Spinnaker No 1	872	81.0
Spinnaker No 2	697	64.78

## FULMAR 32

### SPECIFICATION

Length Overall	31'10"	9.7m	
Length Waterline	26'0"	7.92m	
Beam	10'11"	3.33m	
Draft	Fin Keel	5'3"	1.6m
	Twin Keels	4'0"	1.22m
Displacement	9900lbs	4490kg	
Ballast	Fin Keel	4210lbs	1914kg
	Twin Keels	4210lbs	1914kg
Mast Height	42'6"	19.96m	
<i>SAIL AREAS</i>	<i>sq ft</i>	<i>sq m</i>	
Mainsail	253.0	23.5	
No 1 Genoa	313.0	29.1	
No 2 Genoa	254.0	23.6	
No 1 Jib	194.0	18.0	
No 2 Jib	93.0	8.6	
Spinnaker	760.0	70.6	

## STORM 33

### SPECIFICATION

Length Overall	33'2"	10.11m
Length Waterline	27'0"	8.21m
Beam	11'7"	3.52m
Draft	5'6"	1.68m
Displacement	11310lbs	5130kg
Ballast	4210lbs	1910kg
Mast Height	45'10"	13.9m
<i>SAIL AREAS</i>	<i>sq ft</i>	<i>sq m</i>
Mainsail	233.0	21.61
No 1 Genoa	444.0	41.28
No 2 Genoa	362.0	33.6
No 1 Jib	251.0	23.31
Storm Jib	90.0	8.4
Spinnaker	1045.0	97.16

## STORM 33 CRUISING

### SPECIFICATION

Length Overall	33'2"	10.11m
Length Waterline	27'0"	8.21m
Beam	11'7"	3.52m
Draft	Twin Keels 4'0"	1.22m
Displacement	12355lbs	5604kg
Ballast	4990lbs	2264kg
Mast Height	41'9"	12.73m

<i>SAIL AREAS</i>	<i>sq ft</i>	<i>sq m</i>
-------------------	--------------	-------------

Mainsail	200.0	18.57
No 1 Genoa	333.0	30.95
No 2 Genoa	267.0	24.80
No 1 Jib	212.0	19.69
No 2 Jib	165.0	15.30
Storm Jib	70.0	6.48
Spinnaker	756.0	70.23

# RIVIERA 35

## SPECIFICATION

Length Overall		34'7"	10.54m
Length Waterline		27'6"	8.38m
Beam		12'3"	3.74m
Draft	Fin Keel	4'8"	1.42m
	Twin Keels	4'5"	1.34m
Displacement		15180lbs	6900kg
Ballast	Fin Keel	5707lbs	2588kg
	Twin Keels	5292lbs	2400kg
Mast Height (Above Waterline)		48'11"	14.91m

<i>SAIL AREAS</i>	<i>sq ft</i>	<i>sq m</i>
Mainsail	242.0	22.5
No 1 Genoa	349.0	32.5
Storm Jib	100.0	9.3
Spinnaker	866.0	80.5

## SEAHAWK 35

### SPECIFICATION from Sept. 1988

Length Overall		34'7"	10.54m
Length Waterline		27'6"	8.38m
Beam		12'3"	3.74m
Draft	Fin Keel	4'11"	1.50m
	Twin Keels	3'11"	1.19m
Displacement		12698lbs	5760kg
Ballast	Fin Keel	5733lbs	2600kg
	Twin Keels	6171lbs	2800kg
Mast Height		42'10"	13.05m
<i>SAIL AREAS</i>		<i>sq ft</i>	<i>sq m</i>
Mainsail		240.0	22.3
No 1 Genoa		492.0	45.7
No 2 Genoa		403.0	37.4
No 1 Jib		296.0	27.5
No 2 Jib		221.0	20.5
Storm Jib		83.0	7.7
Spinnaker		850.0	79.0

## FALCON 35

### SPECIFICATION from Sept. 1988

Length Overall		34'7"	10.54m
Length Waterline		27'6"	8.38m
Beam		12'3"	3.74m
Draft	Fin Keel	4'11"	1.50m
	Twin Keels	3'11"	1.19m
Displacement		12588lbs	5708kg
Ballast	Fin Keel	5733lbs	2600kg
	Twin Keels	6171lbs	2800kg
Mast Height		42'10"	13.05m
<i>SAIL AREAS</i>		<i>sq ft</i>	<i>sq m</i>
Mainsail		240.0	22.3
No 1 Genoa		485.0	45.1
No 2 Genoa		398.0	37.0
No 1 Jib		288.0	26.8
No 2 Jib		204.0	19.0
Storm Jib		82.0	7.6
Spinnaker		1135.0	105.4

## **CORSAIR II 36**

### **SPECIFICATION**

Length Overall (excluding rudder)	35'8"	10.87m
Length Waterline	30'5"	9.27m
Beam	12'6"	3.81m
Draft	4'11"	1.590m
Displacement	15500lbs	7037kg
Ballast	6600lbs	2996kg
Mast Height	52'0"	15.85m
<i>SAIL AREAS</i>	<i>sq ft</i>	<i>sq m</i>
Mainsail	296.0	27.23
No 1 Genoa	540.0	49.68
No 2 Genoa	445.0	40.94
No 1 Jib	328.0	30.18
No 2 Jib	228.0	20.97
Storm Jib	115.0	10.58
Trisail	103.0	9.47
Radial Head Glider	936.0	86.11
Radial Head Spinnaker	1296.0	119.23



## SEALORD 39

### SPECIFICATION

Length Overall	38'6"	11.73m
Length Waterline	32'6"	9.9m
Beam	12'2"	4.01m
Draft	5'6"	1.68m
Displacement	18500lbs	8392kg
Ballast	8000lbs	3629kg
Mast Height	50'3"	15.0m
<i>SAIL AREAS</i>	<i>sq ft</i>	<i>sq m</i>
Mainsail	352.0	32.7
No 1 Genoa	615.0	57.1
No 2 Genoa	479.0	44.1
No 1 Jib	352.0	32.7
No 2 Jib	217.0	20.1
Storm Jib	119.0	11.0
Trisail	123.0	11.4
Radial Head Glider	1071.0	99.5
Radial Head Spinnaker	1476.0	137.1

## OCEANLORD 41

### SPECIFICATION

Length Overall	40'6"	12.34m
Length Waterline	33'6"	10.21m
Beam	12'2"	4.01m
Draft	5'6"	1.68m
Displacement	18500lbs	8392kg
Ballast	8000lbs	3629kg
Main Mast Height	50'3"	15.32m
<i>SAIL AREAS</i>	<i>sq ft</i>	<i>sq m</i>
Mainsail	352.0	32.7
No 1 Genoa	615.0	57.1
No 2 Genoa	479.0	44.1
No 1 Jib	352.0	32.7
No 2 Jib	217.0	20.1
Storm Jib	119.0	11.0
Trisail	123.0	11.4
Radial Head Glider	1071.0	99.5
Radial Head Spinnaker	1476.0	137.1

## 10. WESTERLY YACHTS - PRE 1988

INTRODUCTION

EQUIPMENT CHART

## **INTRODUCTION**

Information on the following systems and equipments is contained in the relevant section descriptions itemising current production yachts.

HULL Section

SAILS AND RIGGING Section

GAS SYSTEM Section

ELECTRICAL SYSTEMS Section

MAINTENANCE Section

Systems and equipment peculiar to pre 1988 yacht models are described in the following pages.

# WESTERLY YACHT EQUIPMENT CHART

YACHT	KEEL	RIG	STEERING	ENGINE	TOILET
NIMROD	Fin/Lift	Sloop	Tiller	Outboard	
JOUSTER	Fin/Lift	Sloop	Tiller	Outboard	
WARWICK	Twin	Sloop	Tiller	Petter	
WESTERLY 21	Twin	Sloop	Tiller	Petter	
CIRRUS	Fin	Sloop	Tiller	Volvo MD1	
WESTERLY 22	Triple	Sloop	Tiller	Outboard/Volvo MD1	
NOMAD	Triple	Sloop	Tiller	Outboard/Volvo MD1	
PAGEANT	Twin	Sloop	Tiller	Volvo MD1/6A/7A	
KENDAL	Twin	Sloop	Tiller	Volvo MD1/6A/7A	
J24	Fin	Sloop	Tiller	Outboard	
GK 24	Fin	Sloop	Tiller	Petter/Vire Petrol	SL 400
WESTERLY 25	Triple	Sloop	Tiller	Outboard/Volvo MD1	
WINDRUSH	Triple	Sloop	Tiller	Outboard/Volvo MD1	
TIGER	Fin	Sloop	Tiller	Volvo MD1	
CENTAUR	Twin	Sloop/Ketch	Tiller/Wheel	Volvo MD2	
PEMBROKE	Fin	Sloop/Ketch	Tiller/Wheel	Volvo 11c	SL 400
CHIEFTAIN	Twin	Sloop/Ketch	Wheel	Volvo	SL 400

GRIFTON I	Fin/Twin	Sloop	Tiller	Volvo 7A	SL 400
GRIFTON II	Fin/Twin	Sloop	Tiller	Bukh 20 hp	SL 400
WESTERLY 28	Twin	Sloop	Tiller	Volvo MD1	
GK 29	Fin	Sloop	Tiller	Petter 12hp	
J 30	Fin	Sloop	Tiller	Petter 12hp	
GRIFTON CLUB	Fin/Twin	Sloop	Tiller	Bwkh 10hp	SL401
MERLIN 28	Fin/Twin	Sloop	Tiller	Bukh 2ohp	Lavac
WESTERLY 30	Triple	Sloop	Tiller	Volvo MD2	
RENOWN	Fin	Sloop/Ketch	Wheel	Volvo MD2b/MD3b/11c	
PENTLAND	Twin	Sloop/Ketch	Wheel	Volvo MD2b/MD3b/11c	
LONGBOW	Fin	Sloop/Ketch	Tiller	Volvo MD2b/MD3b/11c	
BERWICK	Twin	Sloop/Ketch	Tiller/Wheel	Volvo MD2b/MD3b/11c	
WESTERLY 33	Fin/Twin	Sloop/Ketch	Whitlock Wheel	MEC OM636/Volvo 17c	Brydon
DISCUS	Fin/Twin	Sloop/Ketch	Edson Wheel	Volvo 17c	
GK 24	Fin	Sloop	Tiller		
VULCAN	Fin/Twin	Sloop	Whitlock Wheel	Volvo	Lavac
WESTERLY 35	Fin	Sloop/Ketch	Whitlock Wheel	MEC OM636/Volvo 17	Lavac
SOLWAY	Twin	Sloop/Ketch	Whitlock Wheel	MEC OM636/Volvo 17	Lavac
CONWAY	Fin/Twin	Sloop/Ketch	Whitlock Wheel	MEC OM636/Volvo 17	Lavac
GALWAY	Twin	Sloop/Ketch	Whitlock Wheel	MEC OM636/Volvo 17	Lavac
MEDWAY	Fin	Sloop/Ketch	Whitlock Wheel	MEC OM636/Volvo 17	Lavac

## 11. STEERING SYSTEMS - PRE 1988

WHITLOCK SYSTEMS  
Cobra and Mamba Systems  
Titan System  
Maintenance

## WHITLOCK SYSTEMS

Three different Whitlock steering systems were fitted to pre 1988 Westerly yachts. The type depends on the year of manufacture and the availability of steering systems. These systems were the Cobra, Mamba and Titan.

### Cobra and Mamba Systems

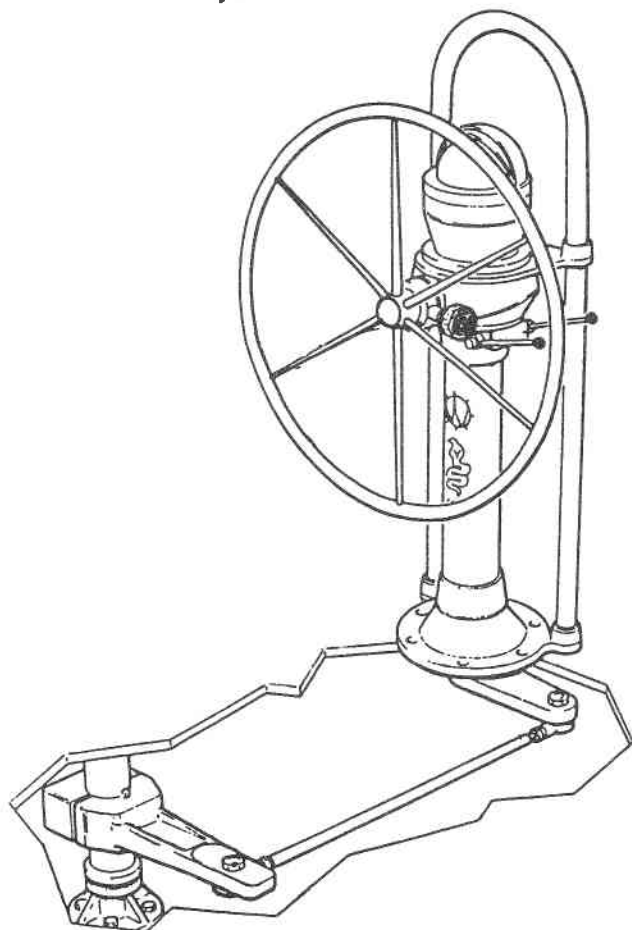

Fig. 1 - Cobra System



This system is extremely robust, reliable and relatively maintenance free. In order for the system to maintain its performance, the following checks are recommended. These checks also apply to the Mamba system, differences are shown where applicable.

- 1 Periodically wash the pedestal exterior with fresh water. Wax with conventional car polish.
- 2 Check that water is not gaining entry to the pedestal assembly. A drain hole is provided in the lower housing to allow for draining of any condensation. If large quantities of water are evident, remove the top cover and reseal using a proprietary silicone rubber product. Take care to remove all old sealant from the pedestal head and top cover before attempting to apply new silicone rubber. If a compass is fitted, check that is also correctly sealed.
- 3 At least twice a season, regrease the lower bearing, on the Cobra system only via the grease nipple. Valvolene XL grease is recommended.
- 4 The bearings in the pedestal, of the Mamba system only, are fully sealed and require no maintenance. The bevel gears are lubricated with a special thixotropic grease which will last many seasons without repacking.
- 5 At least twice a season and prior to any major voyage, check the tightness of the tiller arm and clamp bolt, together with the integrity of the rudder stops.
- 6 At the start of a new season, check that the tightness of the 1/2" UNF nyloc nuts, securing the rose joints to the output lever and tiller lever, are secure.
- 7 On the Cobra system, check that the 5/8" UNF brass lock nuts on the draglink are tight.
- 8 Check that the universal joint pinch bolts are secure.

- 9 Periodically inspect the security of the bevel head and gearbox mountings on the Mamba system. It is essential that the gearbox is not allowed to work loose on its mountings. Testing must be carried out under load, keep the wheel held over to one of the stops and then repeatedly apply a load of 20-30 lbs at the wheel rim, whilst the gearbox is visually inspected for signs of movement at its mountings.
- 10 On the Mamba system, touch up any chips on the paint-work immediately using International Yacht enamel. For larger areas, prior to top coat, use a two-part aluminium etch primer.
- 11 Should any backlash (play) develop at the wheel of the Mamba system, it is possible to reshim the mesh of the gears. Please contact Witlock Marine Steering Co. Limited, 7 Faldo Road Industrial Estate, Barton-le-Cley, Bedfordshire, to arrange for an engineer to service the equipment or, alternatively, provide you with work sheets to enable you to have the adjustment carried out.

### **Titan System**

This system uses two stainless steel wires running in conduit to a quadrant fitted to the rudder stock. The cables are adjusted and tensioned at the quadrant.

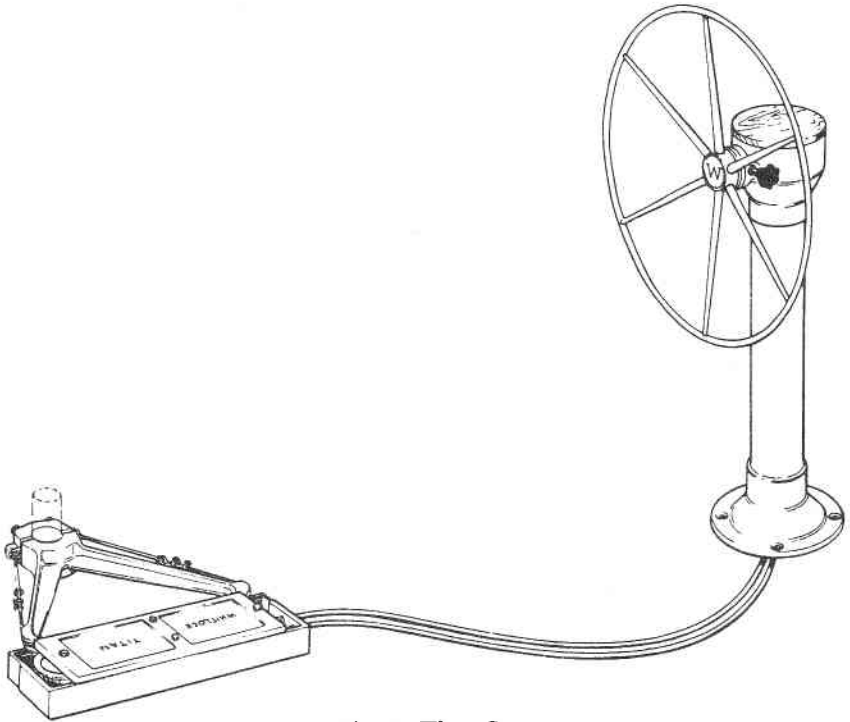

Fig. 2 - Titan System

## Maintenance

### 1 Pedestal Assembly

- 1.1 Periodically wash the paint finish of the pedestal with fresh water. Wax with conventional car polish.
- 1.2 Ensure the stainless steel spiral pin is correctly fitted in the sprocket.
- 1.3 Lubricate bushes using silicone based light grease.
- 1.4 Ensure chain spring clips are correctly fitted.

### 2 Conduit/Wire Assemblies

- 2.1 At the start of the season, inspect conduit for signs of wear or damage.
- 2.2 Lubricate conduits with silicone based light grease.
- 2.3 Examine the wire for signs of wear or damage.
- 2.4 Periodically check the tension in the wires. Slacken the locknut and retaining nut, pull the cable tight by hand and tighten the retaining nut as far as possible by hand. Tighten the locknut to 30ft/lbs using a torque wrench. Check steering for backlash. Do not over-tighten. This will cause excessive wear on the cables, heavy steering and no 'feel'.

### 3 Quadrant

- 3.1 At least twice a season and before any major voyage, check security of quadrant bolts. Lubricate eyebolts and sheave bush with silicone based light grease.
- 3.2 At the start of the season check, rigidity of quadrant unit.

**Note: The stainless steel wire used has a finite life. It is recommended that it be renewed after every fifth season.**

## 12. ENGINE SYSTEMS - PRE 1988

### ENGINE SYSTEMS

#### STERN GEAR

Bukh System

Bronze Inboard Gland Assemblies

## ENGINE SYSTEMS

The older Westerly yachts are fitted with a great variety of engines. These range from Petter, Volvo, MEC and more recently Bukh. Some G24s were fitted with Vire petrol engines. Little specific information is available to cover any of these engines, but the general information in the Engine Systems Section is applicable. Where engine handbooks or data sheets are not supplied when the yacht is purchased, we recommend that the engine make, model and type is identified visually and the appropriate manufacturer is contacted and the relevant literature requested. The following addresses may help:

Bukh - Motorfabriken Bukh A/S, 4400 Kalundborg. Denmark  
Volvo - AB Volvo Penta, S-40508, GOTHENBURG. Sweden  
Petter - Hawker Siddley Marine Limited, Goodridge Avenue, Bristol Road, GLOUCESTER. GL2 6XXX

## STERN GEAR

Various types of stern gear were fitted to older models.

### Bukh System

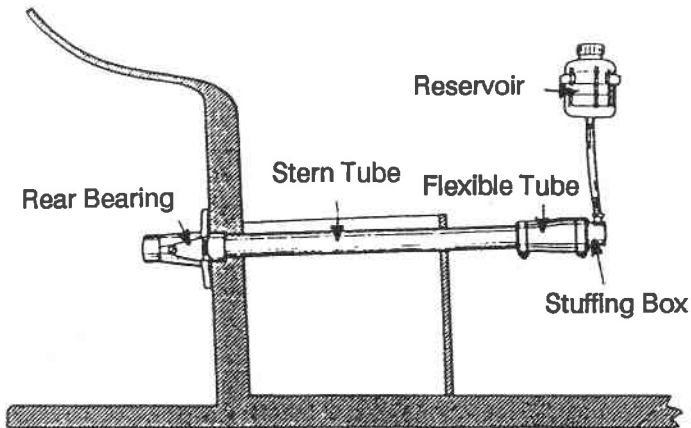

Fig. 1 - Bukh System

## **Notes:**

- 1 The reservoir illustrated in Fig. 1 is an optional extra. It should be mounted approximately 0.25m above the water line and filled with outboard gear oil.**
- 2 Every 3 seasons, renew the 3 ring seals in the stuffing box (A).**
- 3 Excessive oil consumption indicates defective ring seals.**

## **Bronze Inboard Gland Assemblies**

Some early yachts are fitted with bronze inboard gland assemblies with centralising bearings which require regular greasing. This can be achieved using a remote mounted stern gland greaser.

## **13. WATER/WASTE SYSTEMS - PRE 1988**

### **WATER/WAST SYSTEMS**

#### **LAVAC MARINE TOILET**

Operating Instructions

Maintenance

Winterisation

Pump Valves

Spare Parts

#### **LAVAC TOILET WITH HOLDING TANK**

Operation

#### **SL 400 SERIES MARINE TOILET**

Operating Instructions

Spare Parts



## WATER/WASTE SYSTEMS

Some older yachts are fitted with the Brydon marine toilet, but mainly the Lavac and SL 400 toilets are used.

### LAVAC MARINE TOILET

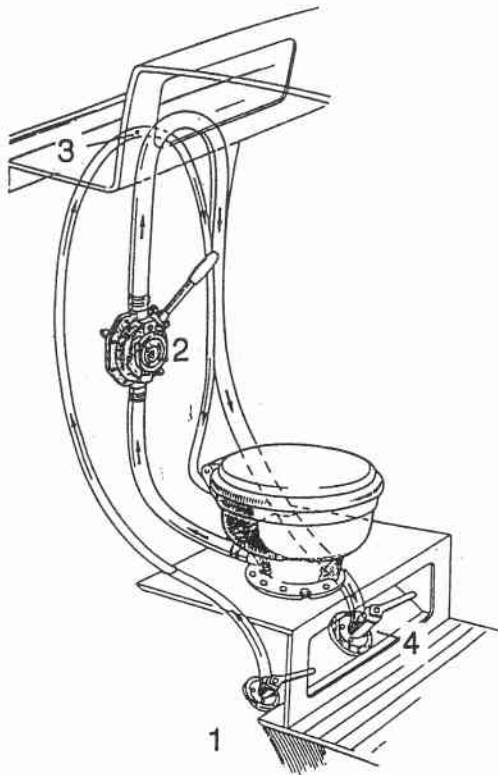

1 - Inlet Seacock  
2 - Pump

3 - Air Bleed Valve  
4 - Outlet Seacock

Fig. 1 - Lavac Toilet

## **Operating Instructions:**

- 1 Open inlet and outlet seacocks.
- 2 Use the toilet.
- 3 Close the lid and sit on it to ensure it seals.
- 4 Operate the pump for 8 - 10 slow strokes.
- 5 Pause for a few seconds.
- 6 Operate the pump for a further 8 - 10 slow strokes.
- 7 Wait for a few seconds for the vacuum to clear.
- 8 Raise lid.
- 9 Operate the pump until the bowl is clear of water.
- 10 Close inlet and outlet seacocks.

## **Maintenance**

### **Pump Blockage**

Should a blockage occur in the pump, pour half a bucket of water in the bowl, leave the lid open and pump with firm strokes until the water leaves the bowl. Repeat if necessary. If this does not work, the pump must be dismantled.

### **Bleed Hole Blockage**

The small bleed hole in the inlet pipe (Fig. 1, Item 3) must be kept clear. If it becomes blocked, it will prevent correct operation of the toilet. Take care if painting in this area or when hanging clothing above the toilet.

## **Winterisation**

When laying up the yacht for the winter, it is recommended that the toilet be well flushed and then dried. Carry out the operation in 'Pump Blockage' several times. Remove the outlet hose at the seacock and pump the toilet into a bucket until dry. Reconnect the outlet hose and ensure the seacocks are closed.

## **Pump Valves**

After 2-3 years, the pump valves may 'fur-up' from salt water action. This scaling is easily removed by flexing the rubber and scraping gently. It is recommended that the pump is checked every 2 years and descaled as necessary.

## **Spare Parts**

Spare parts and repair information can be obtained from Westerly Yachts Ltd. or direct from:

Blake & Sons Limited, PO Box 15, Sunbeam Works,  
GOSPORT, Hants. PO12 2HG Tel: (0705) 583322

## **LAVAC TOILET WITH HOLDING TANK**

Some export yachts are fitted with a holding tank waste system as illustrated in Fig. 2.

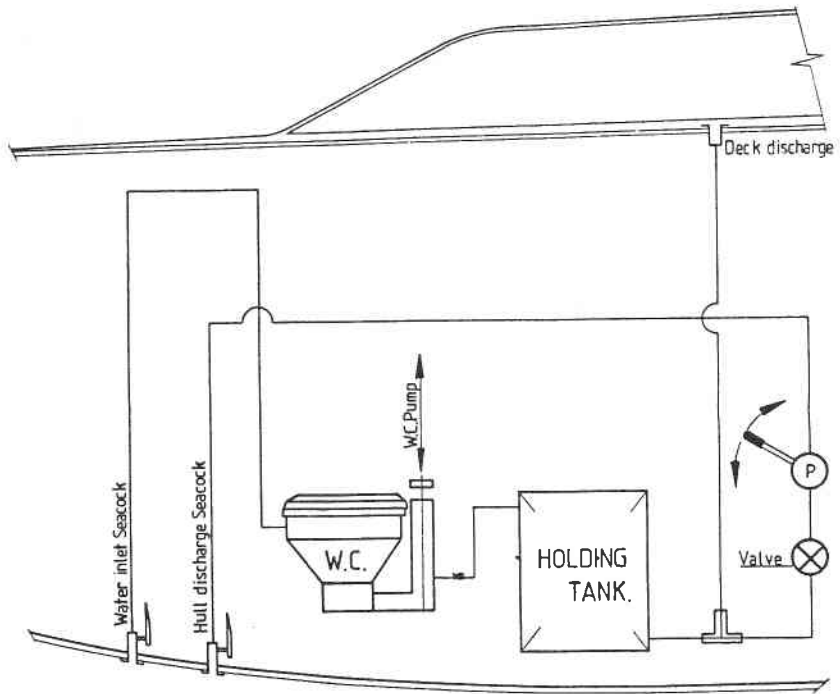

Fig. 2 - LAVAC Toilet with Holding Tank

**Operation:** Valve positions for operation of the system are detailed in Table 1 - Valve Positions.

OPERATION	VALVE POSITION		
	A	B	C
Pump waste from W.C to hull discharge.	2	1	Closed
Pump waste from W.C to holding tank.	2	2	Closed
Pump waste from holding tank to hull discharge.	1	1	Closed
Pump waste from holding tank to deck discharge.	Closed	Closed	Open

Table 1 - Valve Positions

### SL 400 MARINE TOILET

The SL 400 marine toilet has been fitted to several of the older Westerly yacht models. It is very simple to operate and maintain.

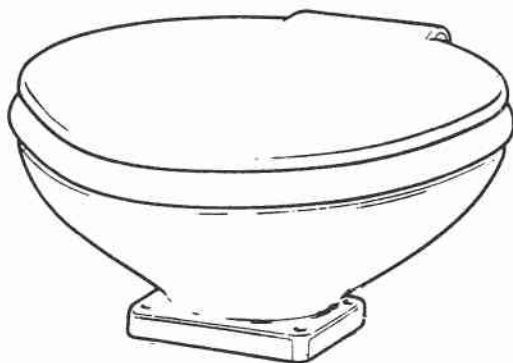

Fig. 3 - SL 400 Toilet

## **Operating Instructions:**

- 1 Open inlet and outlet seacocks.
- 2 Pull handle towards bowl (A) and pump up and down.  
This will flush and discharge simultaneously.
- 3 Push handle away from bowl (B) and pump up and down.  
This will empty the bowl.
- 4 Close inlet and outlet seacocks.

**Note: Use only very absorbent toilet paper.**

## **Spare Parts**

Spare parts and repair information can be obtained from Westerly Yachts Limited or from:

Simpson-Lawrence Limited, 218/228 Edmiston Drive,  
GLASGOW. G51 2YT Tel: (041) 4275331.

## **Operating Instructions:**

- 1 Open inlet and outlet seacocks.
- 2 Pull handle towards bowl (A) and pump up and down.  
This will flush and discharge simultaneously.
- 3 Push handle away from bowl (B) and pump up and down.  
This will empty the bowl.
- 4 Close inlet and outlet seacocks.

**Note: Use only very absorbent toilet paper.**

## **Spare Parts**

Spare parts and repair information can be obtained from Westery Yachts Limited or from:

Simpson-Lawrence Limited, 218/228 Edmiston Drive,  
GLASGOW. G51 2YT Tel: (041) 4275331.